

ASD Quarterly Bulletin October – December, 2015

Accelerator Systems Division provided excellent support for APS operation and finished Run 2015-3 with 118 hours of the Mean Time Between Faults (MTBF) and 98.7% of the Machine Availability. Several other developments and events took place in the last quarter of 2015 and are highlighted here. The report from the **RF Group** will be included in the next quarterly report.

The Accelerator and Operations Group

AOP has developed a new procedure for user-requested steering. Previous procedure required switching from global orbit correction to local correction around the sector under steering, which resulted in increased global orbit noise and also introduced permanent orbit steps of several microns. The new method performs the entire steering using the same global orbit correction thus eliminating orbit steps, keeping the noise at the same low level, and also making the whole process simpler and shorter.

An abort kicker was designed and installed in the storage ring to protect two superconducting undulators from quenching during beam dumps. AOP group developed an operational configuration for the kicker and successfully tested it during machine studies. The abort action is triggered by the beam dump and exact trajectory of the dumped beam is controlled by the kicker voltage and by the delay of the kicker pulse relative to the signal of the RF muting. As the final test, the kicker was used during the last week of the operation.

AOP group members continued working on issues related to the injector upgrade for APS-U demanding high bunch charges, i.e., completed commissioning of 1-Hz injector operation, stored a very high charge of 23 nC in PAR. Among other APS-U topics, the work is currently concentrated on developing lattices that would allow accumulation.

AOP also worked on the design of the APS lattice that would allow reduced horizontal size in the straight section vacuum chamber suitable for installation of the helical superconducting undulator (HSCU). As the preliminary result, the lattice that would allow for horizontal gap at the location of the HSCU as small as 10 mm was successfully tested during machine studies.

AOP also continued photo-cathode gun commissioning: very short (few picoseconds) and very intense pulse of electrons has been transported beyond PAR and into the booster bypass.

The Diagnostic Group

In summer and fall of 2015, the diagnostics group demonstrated for the first time use of the grazing incident x-ray beam position monitor (GRID XBPM) during operations in datapool (slow) orbit feedback. Figure 1 shows the results obtained during the summer run. The plots show horizontal and vertical x-ray beam positions at the GRID. The red curve is before the GRID was in feedback. The various colors indicate the various bunch patterns used during the summer run. One sees that in a given week the beam position stability is better than 5 microns (frequently much better). The discontinuities correspond to maintenance and machine studies periods. The red lines on each plot indicate the beam stability requirements for APS-U which are met. Similar results with the S27 ID GRID in feedback were obtained in the Fall run.

Horizontal beam positions in 60-days of User Operations 6/29 – 8/28

Vertical beam positions in 60-days of User Operations 6/29 – 8/28

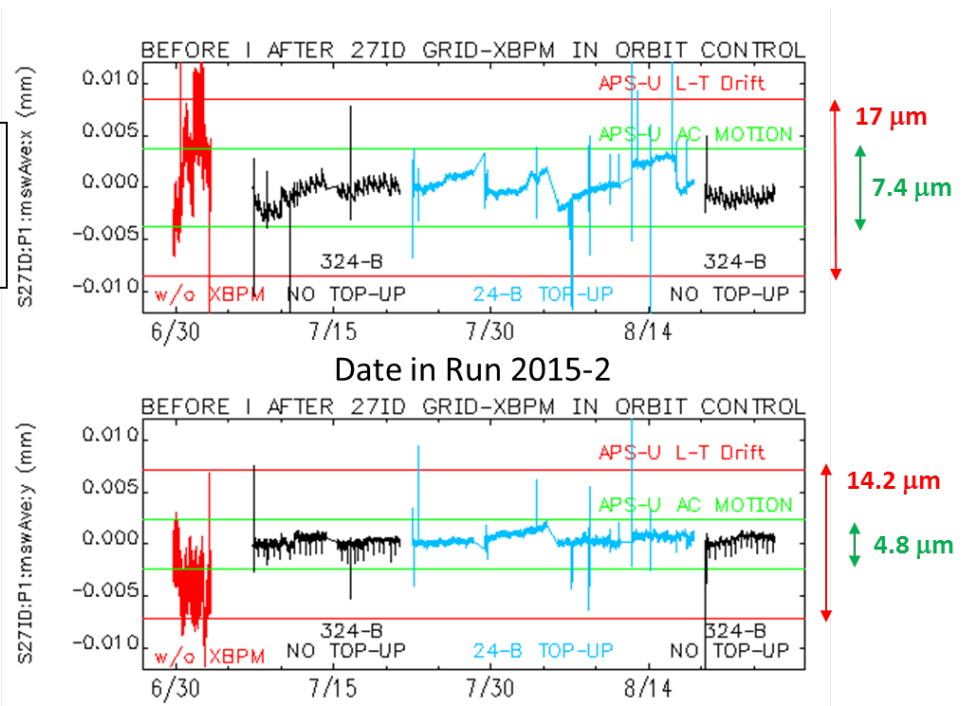

Fig. 1. Showing results of the S27 GRID in datapool (slow) orbit feedback. The top/bottom plot shows horizontal/vertical positions at the GRID. The red curve is before the GRID was in feedback. The various colors indicate the various bunch patterns used during the summer run.

Significant progress was achieved in development of precision current measurement for APS-U power supplies based on a DCCT. Figure 2 shows current measurement system hardware. Current measurement requirements for APS-U power supplies are in the ~5 ppm range so current measurement accuracy and stability better than a few ppm is required. Figure 3 shows the results of a current measurement performed at 10 A showing stability greater than 10 ppm. Extrapolated to 200 A which is the MBA requirement, 10 ppm at 10 A becomes 1 ppm at 200 A. Further development requires fabrication precision current source hardware capable of up to 200 A source current to demonstrate the measurement accuracy and stability of typical MBA unipolar upgrade power supply. In addition precise calibration of the DCCTs for each MBA power supply will be developed and tested.



Fig. 2. DCCT chassis developed to perform precision current measurements for APS-U power supplies.

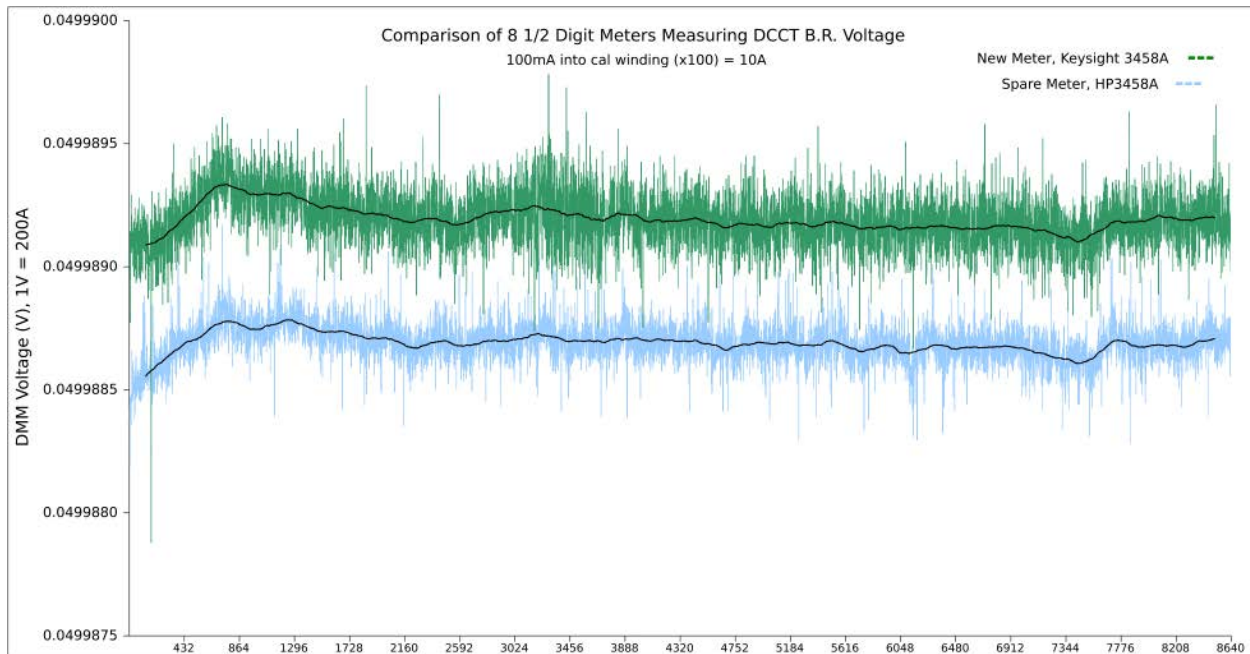

Fig. 3. Graph showing DCCT precision current measurement demonstration. The blue and green traces are data from two different digitizers showing a small offset of 0.5 ppm which would be calibrated out. Absolute stability over time is measured to be greater than 10 ppm at 10 A which is greater than 1 ppm when referenced to 200 A full scale.

The Magnetic Devices Group

Per Sector 2 user's request the replacement for 55-mm period undulator has been prepared. A 33-mm period undulator has been tuned and is ready for the installation Sector 2 straight this coming shutdown. A new 1.08-m long SCU18-2 magnet has been fabricated. The cryogenic tests and quench training have been completed. This device will replace short SCU0 prototype at Sector 6. APS-U quadrupole magnet has been characterized at the MM bench at the Bldg.314. The LCLS HGVP undulator prototype has been tuned and undergone through multiple mechanical and environmental tests. The HGVPU met or exceeded all LCLS-II undulator specifications and has been chosen by the LCLS-II project management as a new baseline undulator for hard x-ray FEL line. The comprehensive cryogenic and magnetic tests of the LCLS SCU prototype based on NbTi wire have been successfully completed. The prototype met all LCLS undulator requirements. Tests of Nb₃Sn-based SCU, built by LBNL, will start in January, 2016.

The Power Systems Group

The major effort for the operation support was on the upgrade of the storage ring quadrupole magnet power converters. In the last quarter the PS group upgraded 34 quad power converters. So far a total of 295 quad power converters were upgraded. Also in the ongoing effort, the four power supplies for the GESPAC power supply control units were replaced.

The development of the bipolar power supply controller with a fast communication interface for the APS-U real-time feedback control system has achieved a major goal that is to identify the appropriate communication protocol and the hardware components. The chosen communication interface is an LBNL Gigabit Ethernet design with UDP protocol. It was confirmed that this design can achieve the required fast communication with a latency less than 10 microseconds. The hardware components and the configuration of the controller are shown in Figure 4.

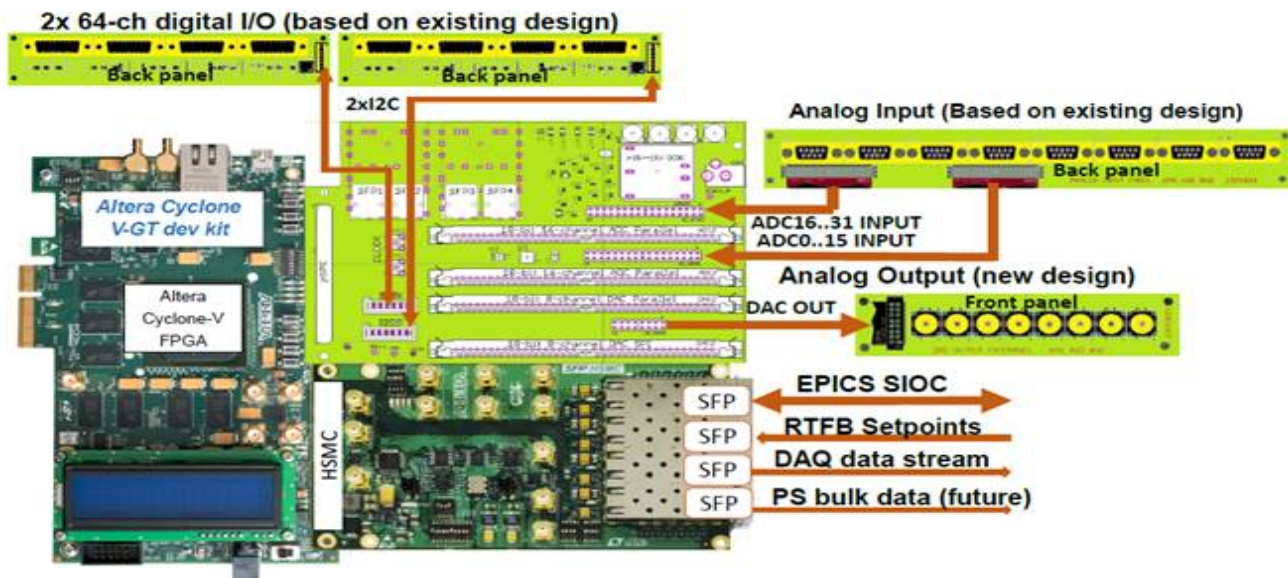

Fig. 4. The prototype controller for the fast corrector power supply.

The development of the first prototype of the fast corrector power supplies was completed. The first prototype achieved a small signal (0.5%) bandwidth of 10 kHz as required by the APS-U. The second iteration of the design is in progress.