

Modularity and Integration of  
**Instrument Control Hardware**  
at the ESS

Thomas Gahl  
Group Leader Motion Control & Automation

[www.europeanspallationsource.se](http://www.europeanspallationsource.se)

October 23, 2014

- Neutron Production & Instruments at ESS
- Modular Instrument Control Concept
- Timing System for Synchronisation and Time Stamping
- Requirements Motion Control
- Organisational Challenges
- Internal and external (in-kind) Interfaces
- Status Motion Control
- Acknowledgements

# Neutron Instrumentation

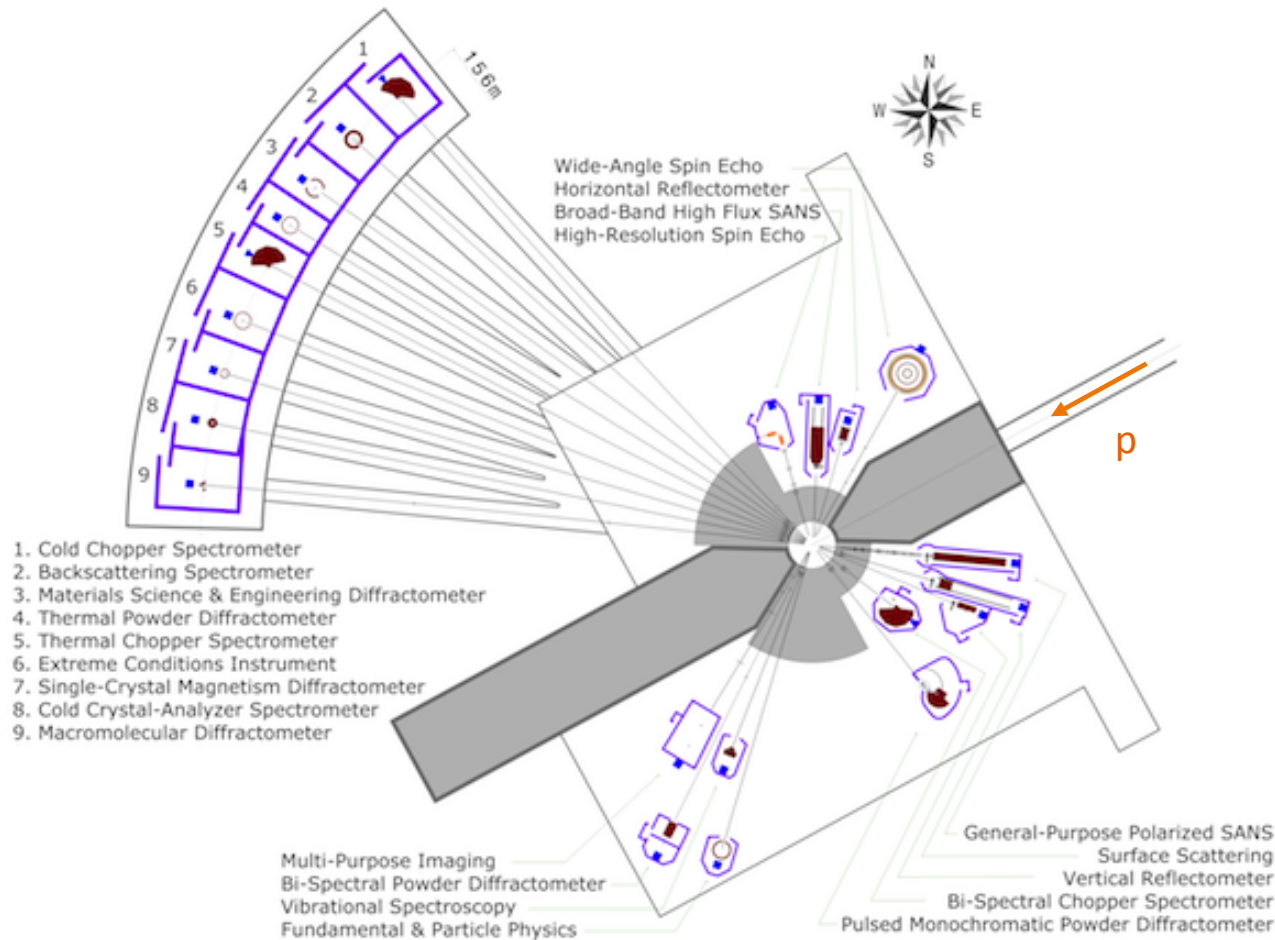

- Target produces fast neutrons (several GeV, like IFMIF facility)
- 2 Moderators, slowing down the neutrons into meV and eV range
- Neutron Instruments = Neutron Beam Lines
- 4 Groups of Instruments (different lengths)

# Time Structure of the Neutron Beam

- 14 Hz rep rate
- 71.4 ms cycle time
- 2.86 ms pulse time
- 4% duty cycle
- 200 – 2000 m/s

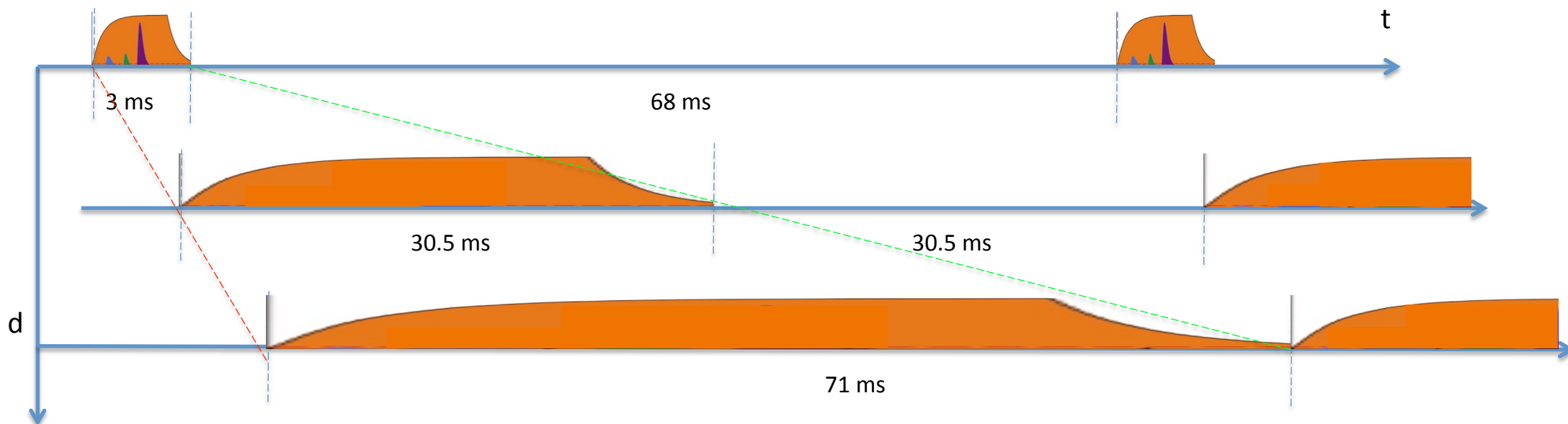
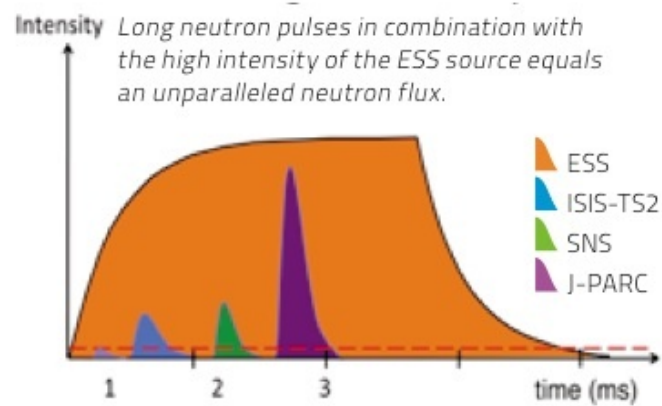

# Long Neutron Instrument

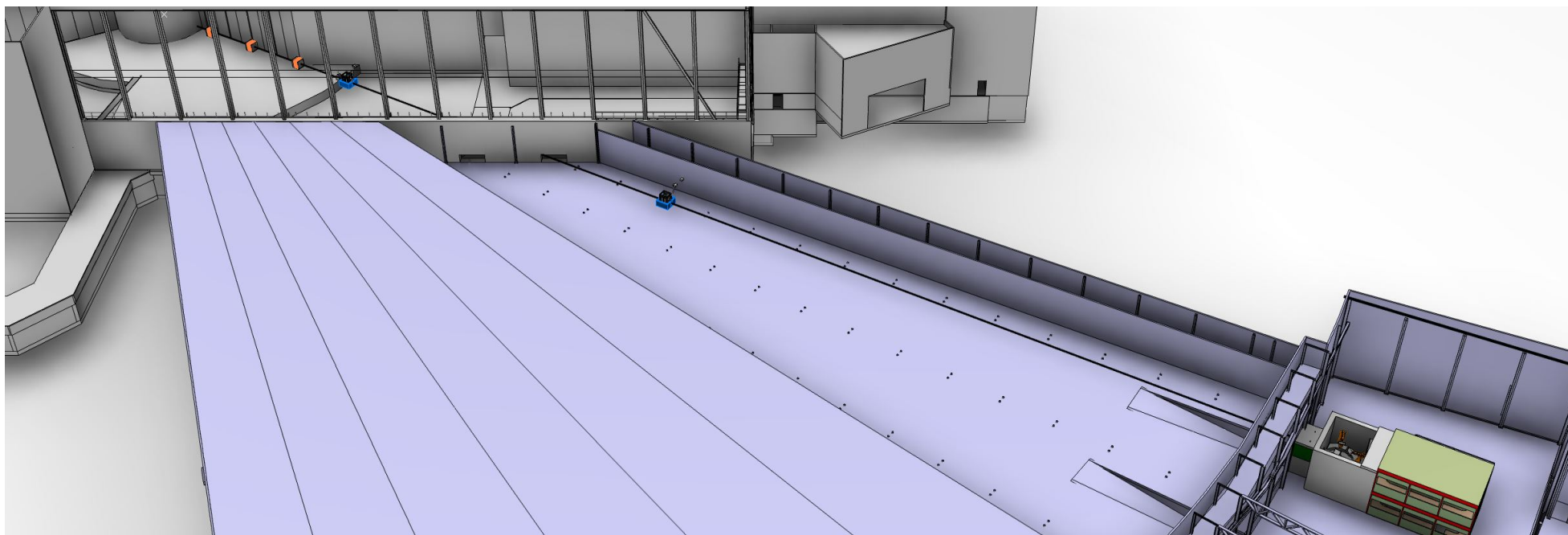

160m

→ n

Beam Extraction + Bunker Area

Beam Transport & Conditioning Area

Sample Area

# Modular Instrument Control Concept

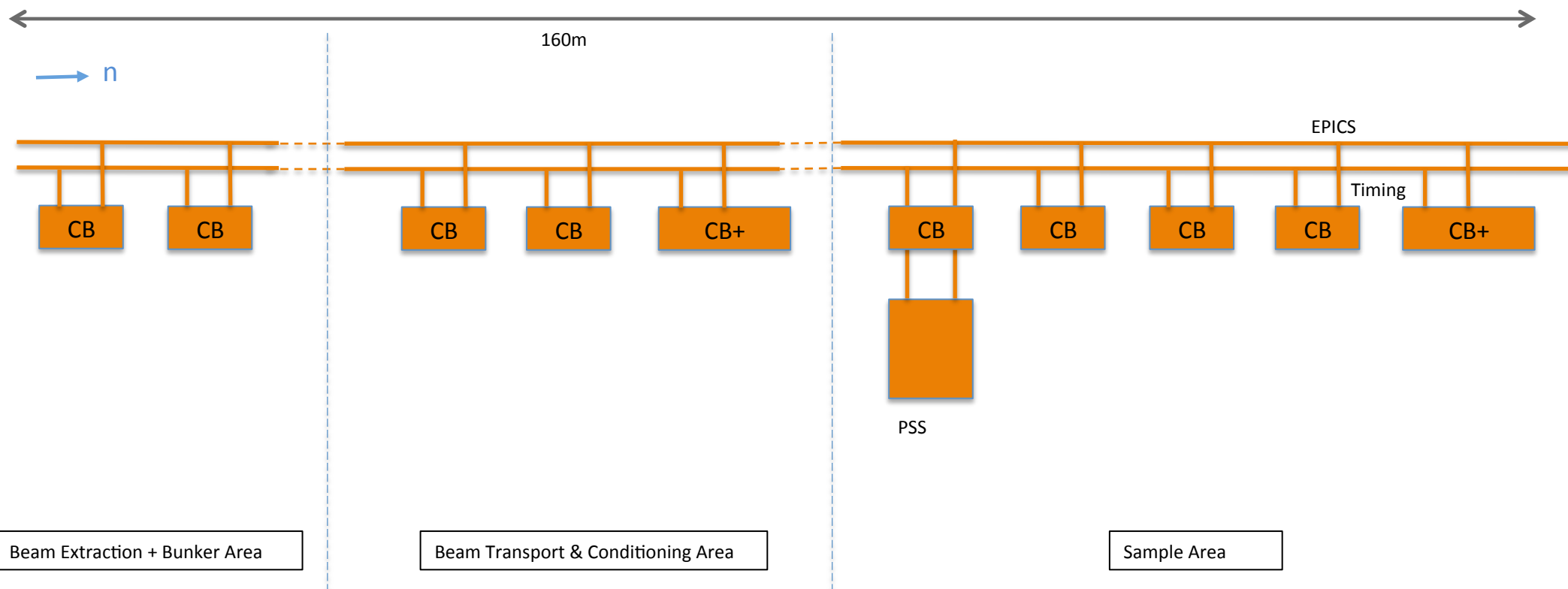
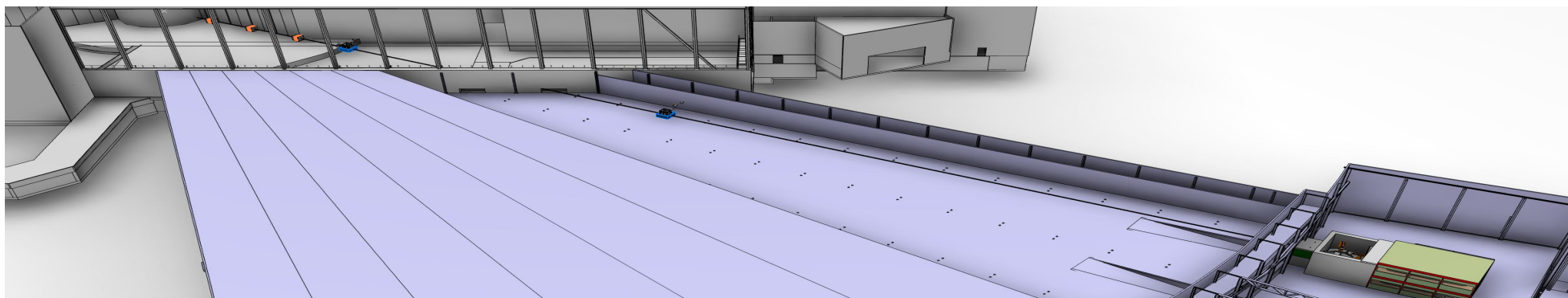

# Modular Instrument Control Concept

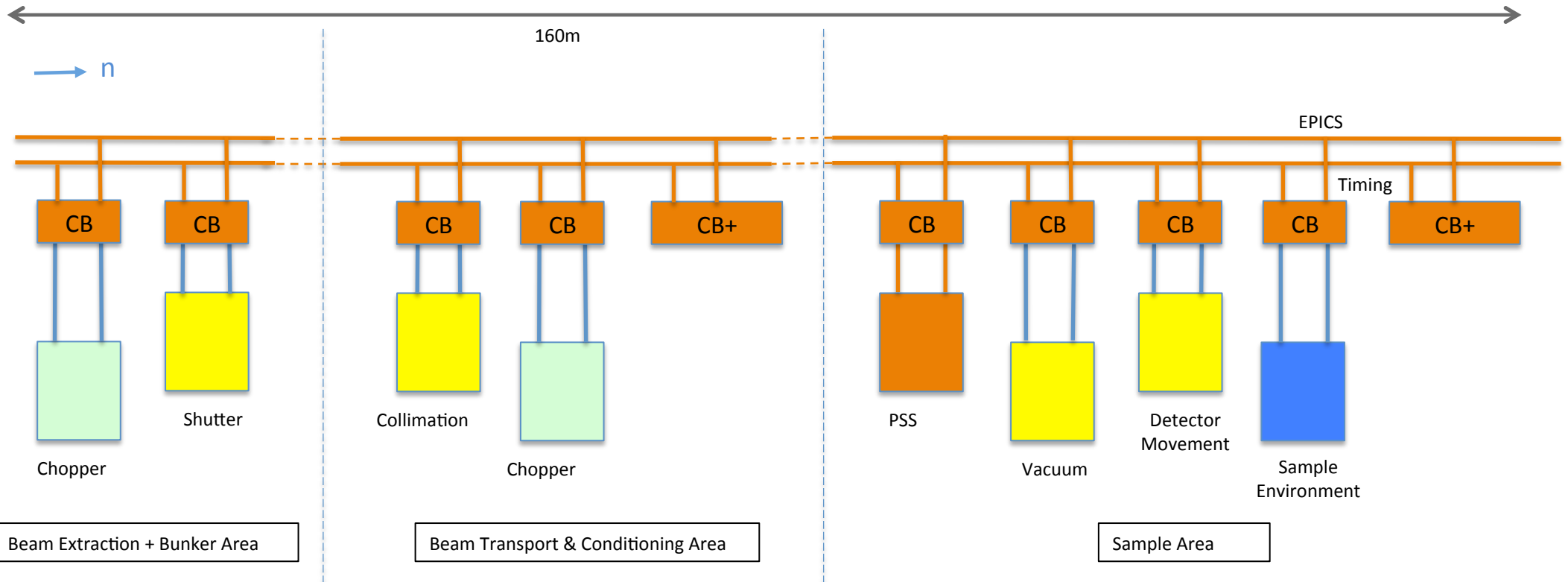
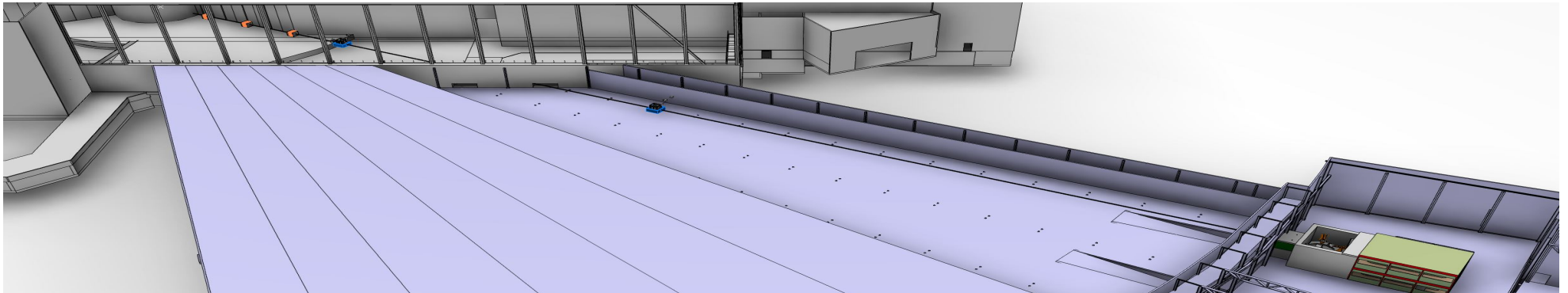

# Modular Instrument Control Concept

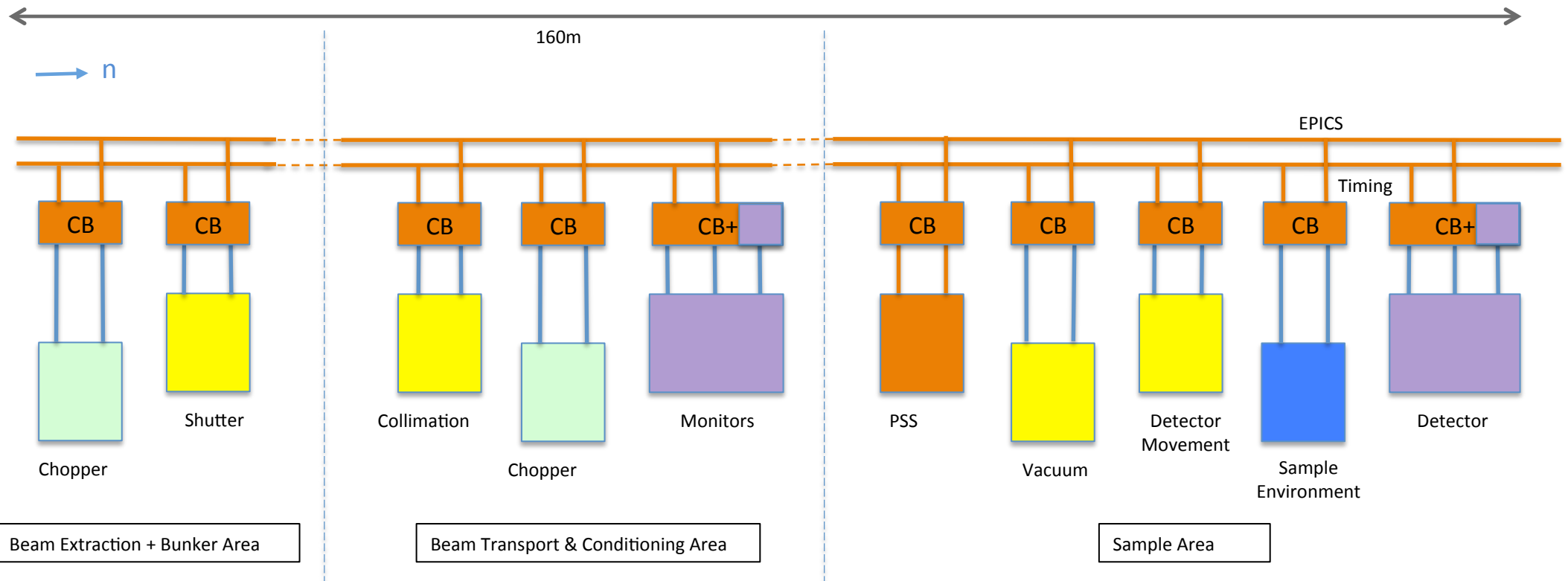
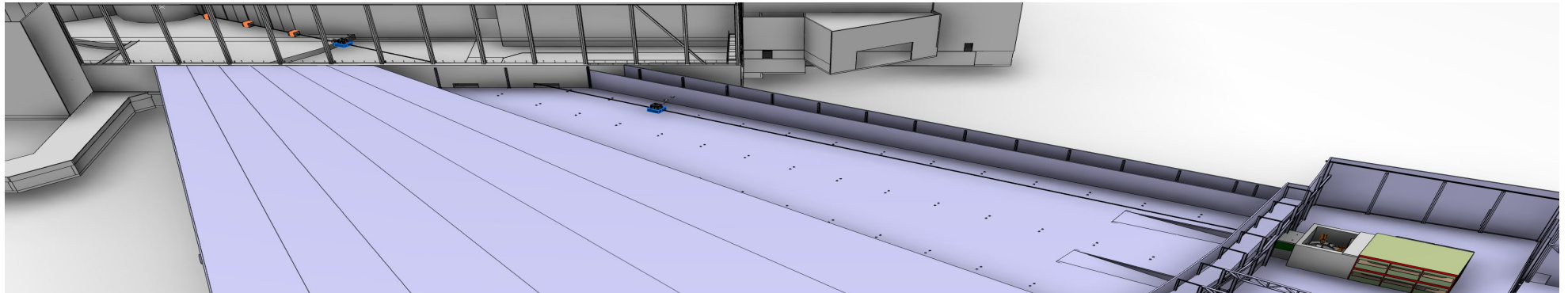



# Modular Instrument Control Concept

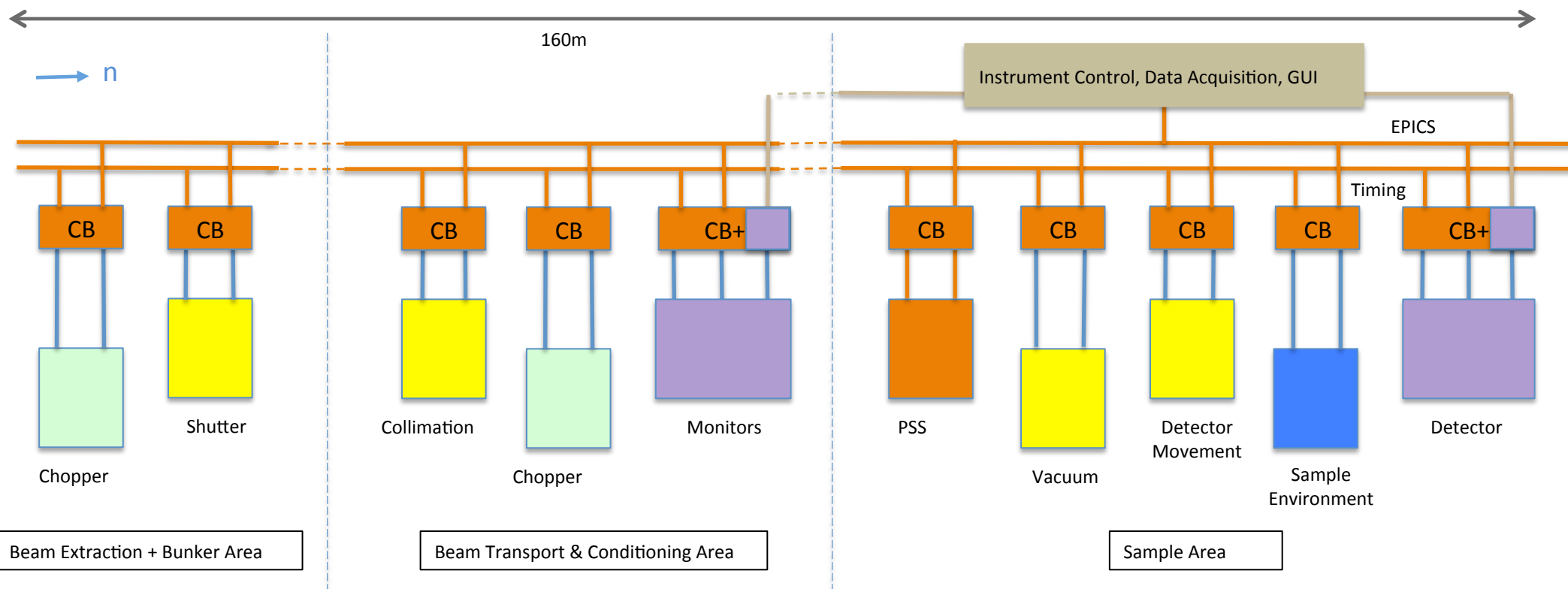
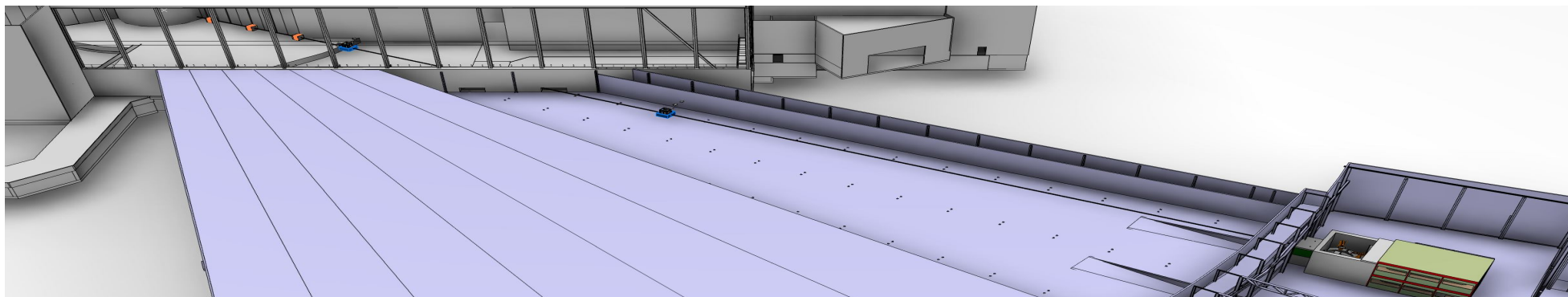

# Modular Instrument Control Concept

- What can (or has to) be done locally will be done locally
- Clear functionalities and interfaces for a single box, avoid direct interconnects
- Linked together by an already existing facility wide network infrastructure

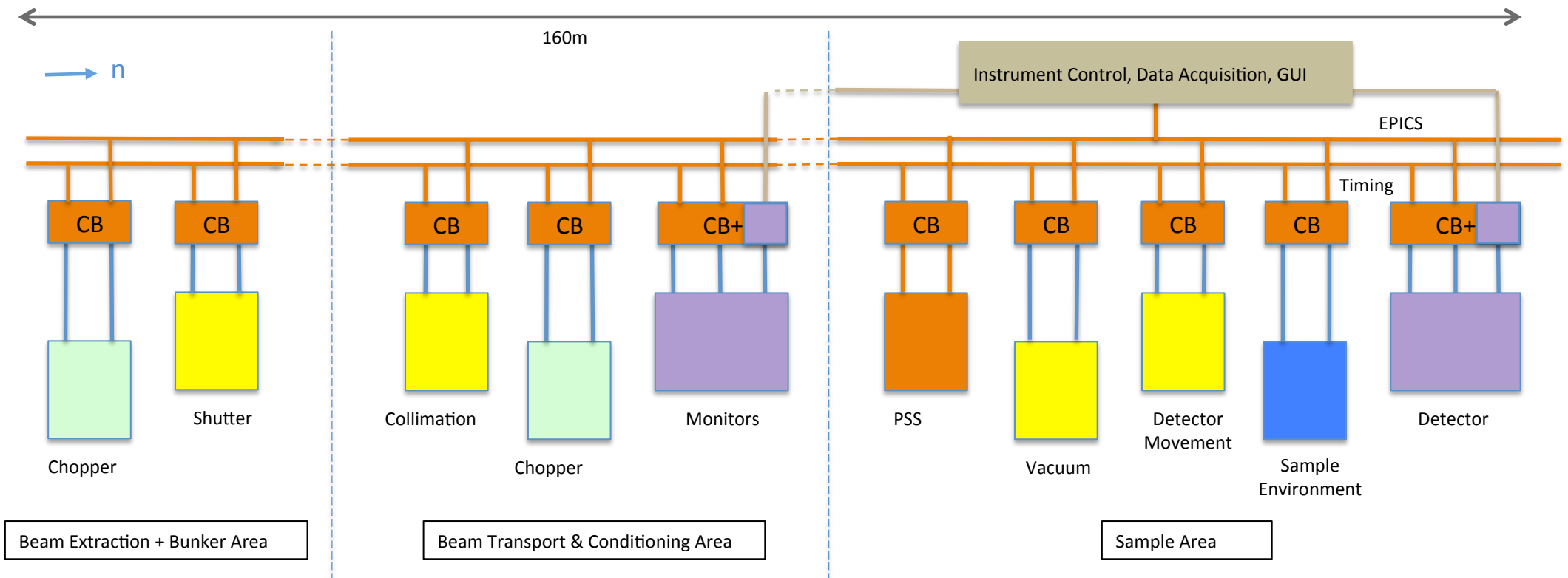

# Diagnostics

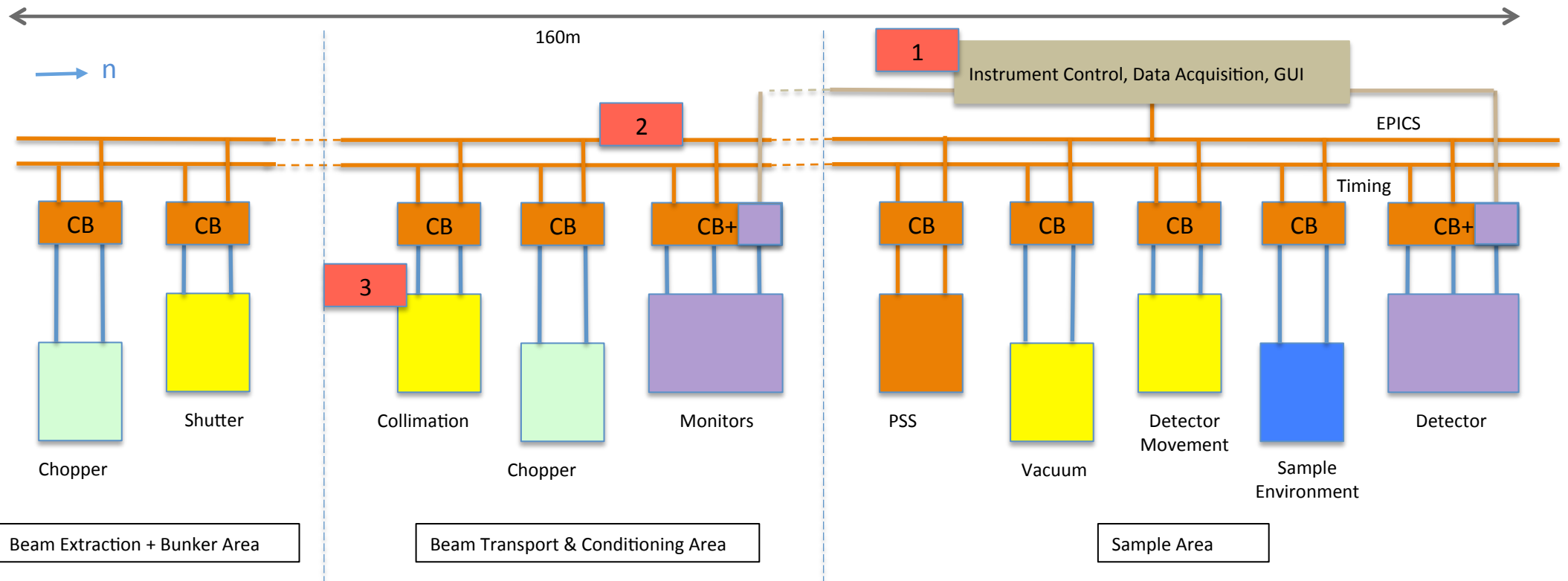
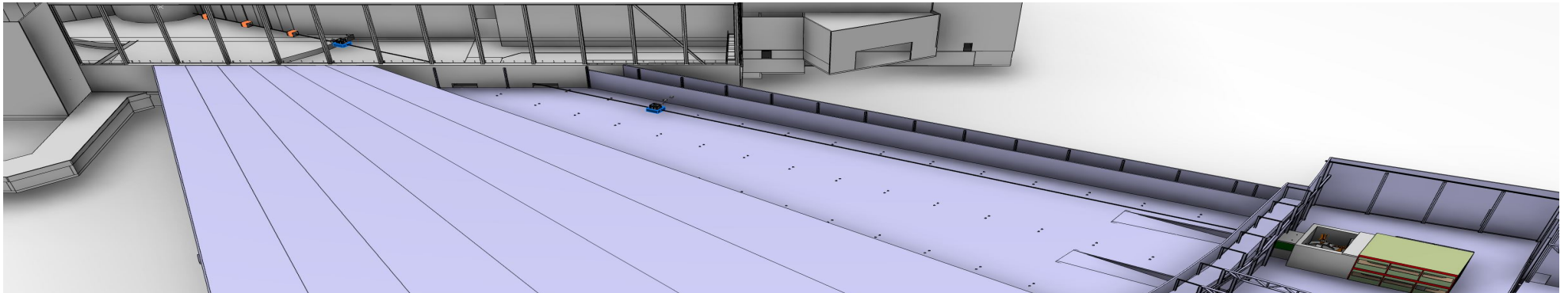

# Requirements on Timing System

- Coupling of all timing to one single source
- Everywhere in the facility available, (time-) compensated cable lengths
- Jitter 10 ns, precision of time stamp 100 ns

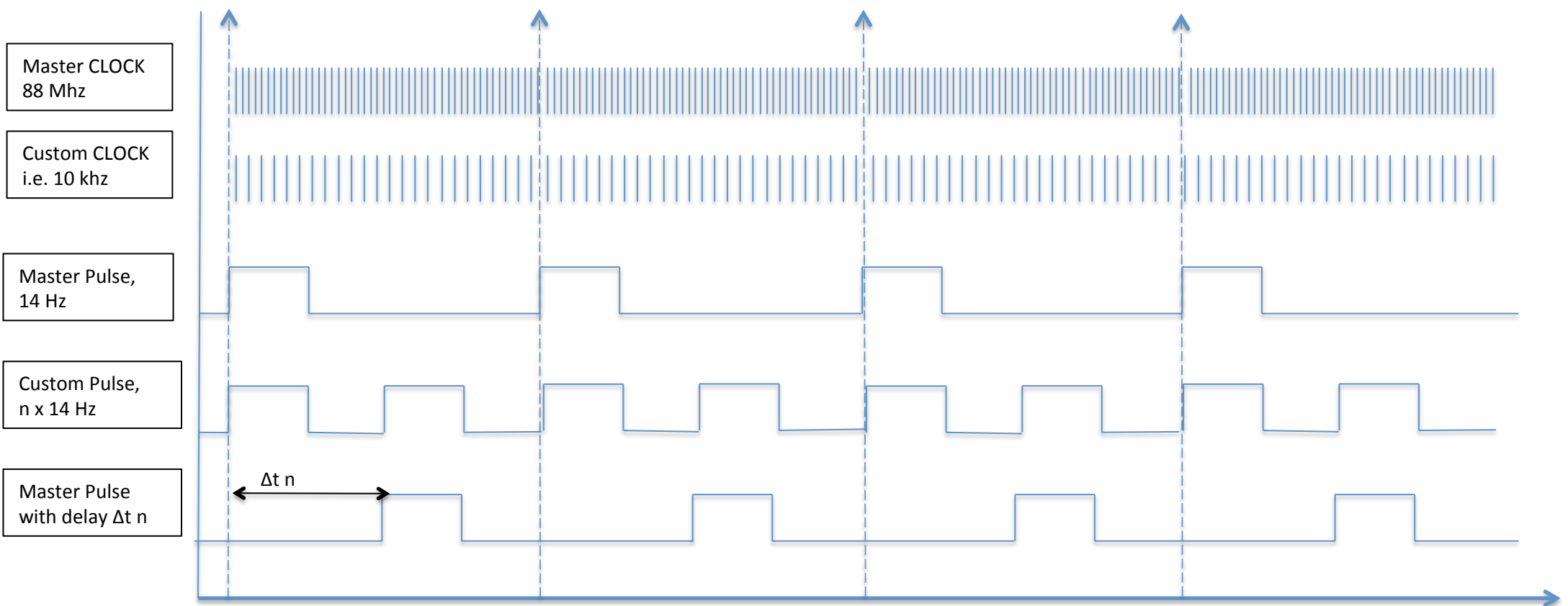

# Motion Control: Time Stamping

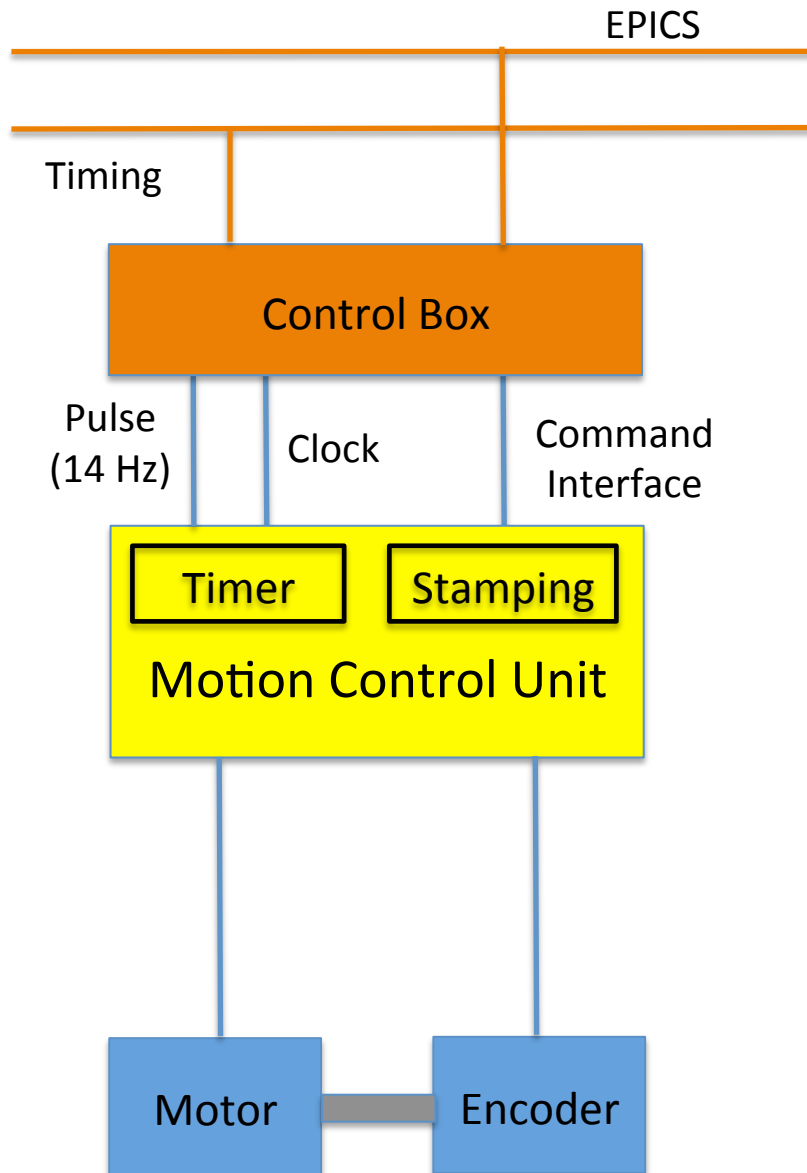

- Transfer absolute timing information from Control Box to the local HW control unit:
- Synchronise a timer on the control unit
- Timestamp in the control unit direct readings of the sensor with minimal latencies
- Transfer the sensor readings through the Control Box into EPICS
- Synchronously vs. asynchronously

# Motion Control: Time Stamping

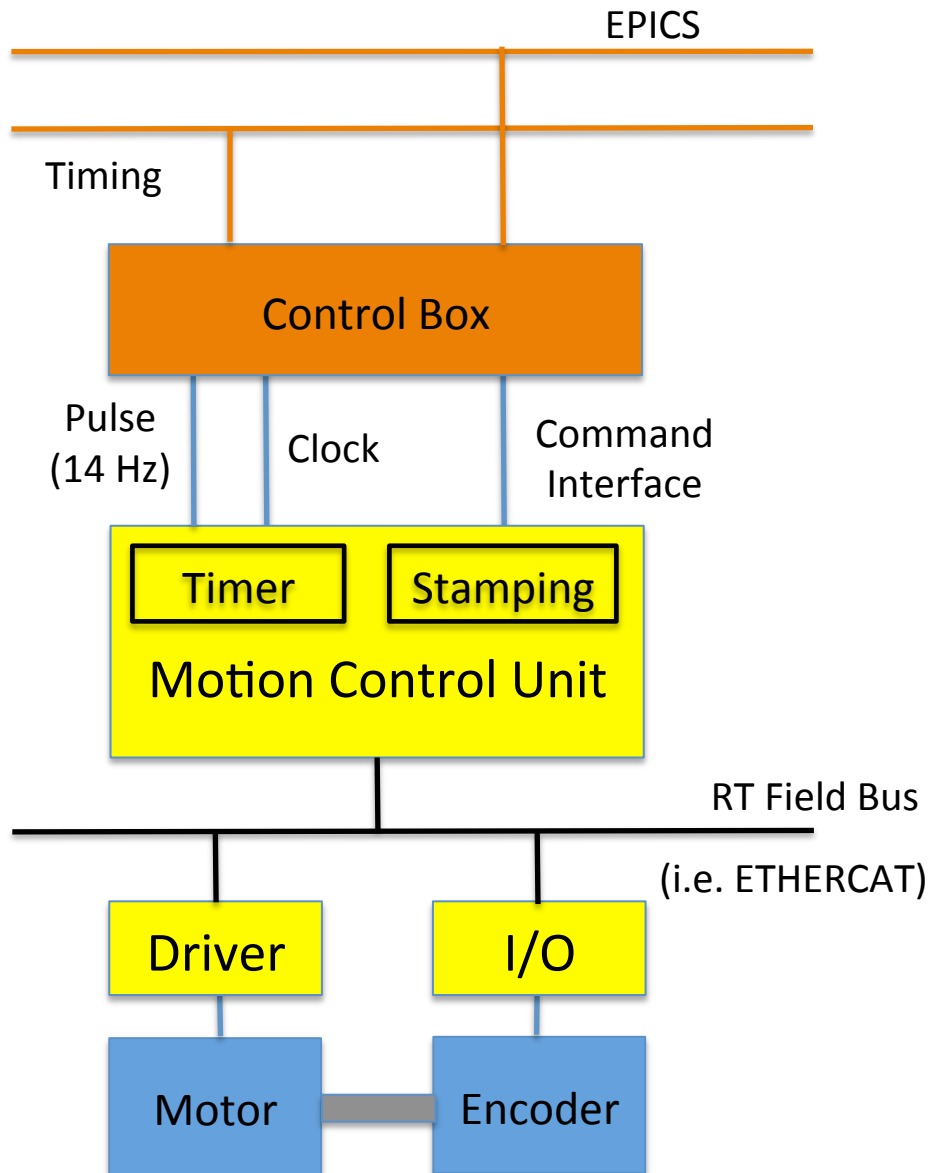

- Transfer absolute timing information from Control Box to the local HW control unit:
- Synchronise a timer on the control unit
- Timestamp in the control unit direct readings of the sensor with minimal latencies
- Transfer the sensor readings through the Control Box into EPICS
- Synchronously vs. asynchronously
- Local distribution of control unit functionalities with real time field busses

# Motion Control: Top Requirements

- Time stamping + 14 Hz synchronisation
- Multi-axes synchronisation
- Free configurable trajectories
- Decentralisation through field bus with real-time capabilities
- Modular and scalable (in terms of performance and price)
- Diagnostics (preemptive maintenance)
- EPICS integration
  
- Components for high radiation environment
- Stepper motors, DC, DC brushless, piezo
- Encoder inc. quad., abs. SSI, resolver, (analog), (BiSS-C)

# Organisational Challenges: Time Line

- Prepare & standardise technologies before instruments are built

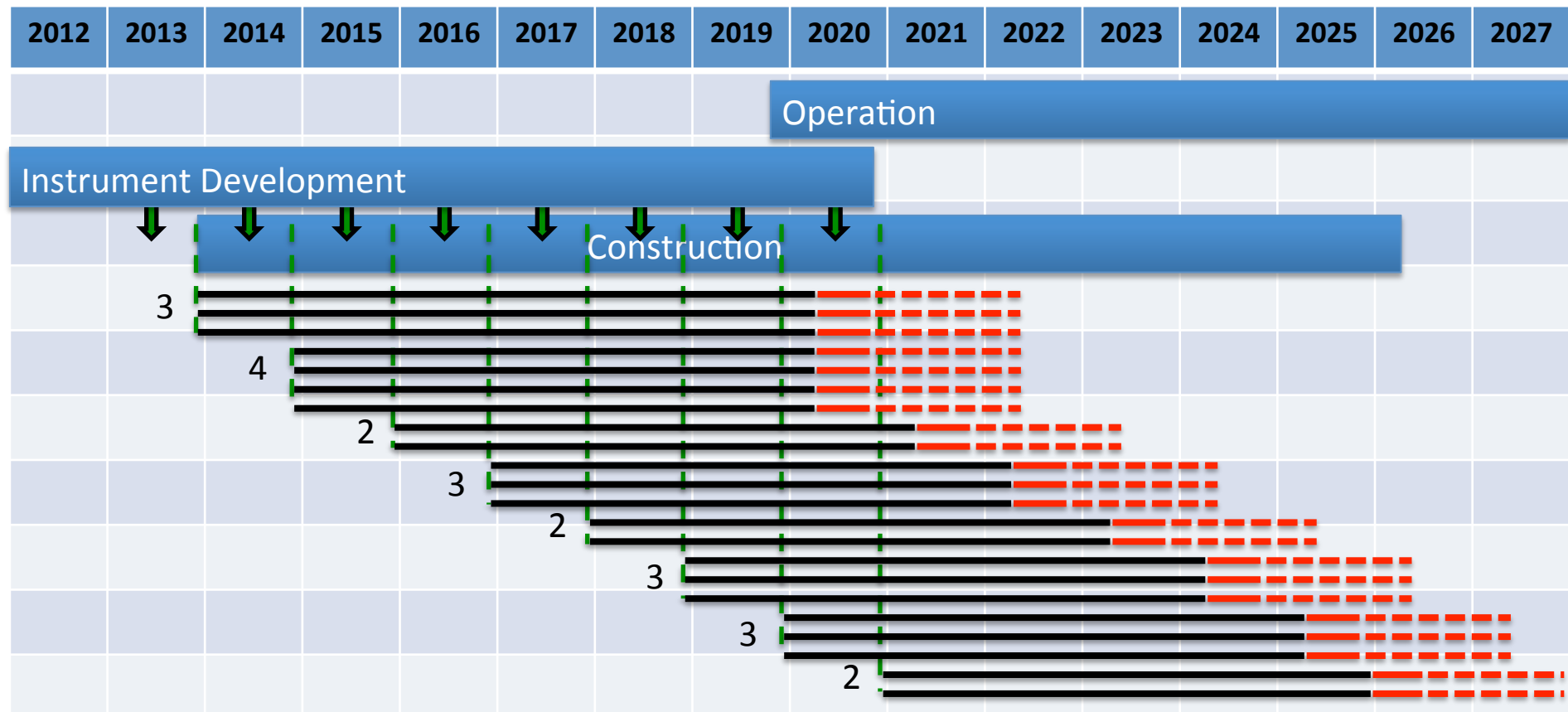



# Organisational Challenges: Internal Interfaces

- Strong interaction between machine and beam line tech groups
- Building overlapping interfaces

# Organisational Challenges: Internal Interfaces

- Strong interaction between machine and beam line tech groups
- Building overlapping interfaces

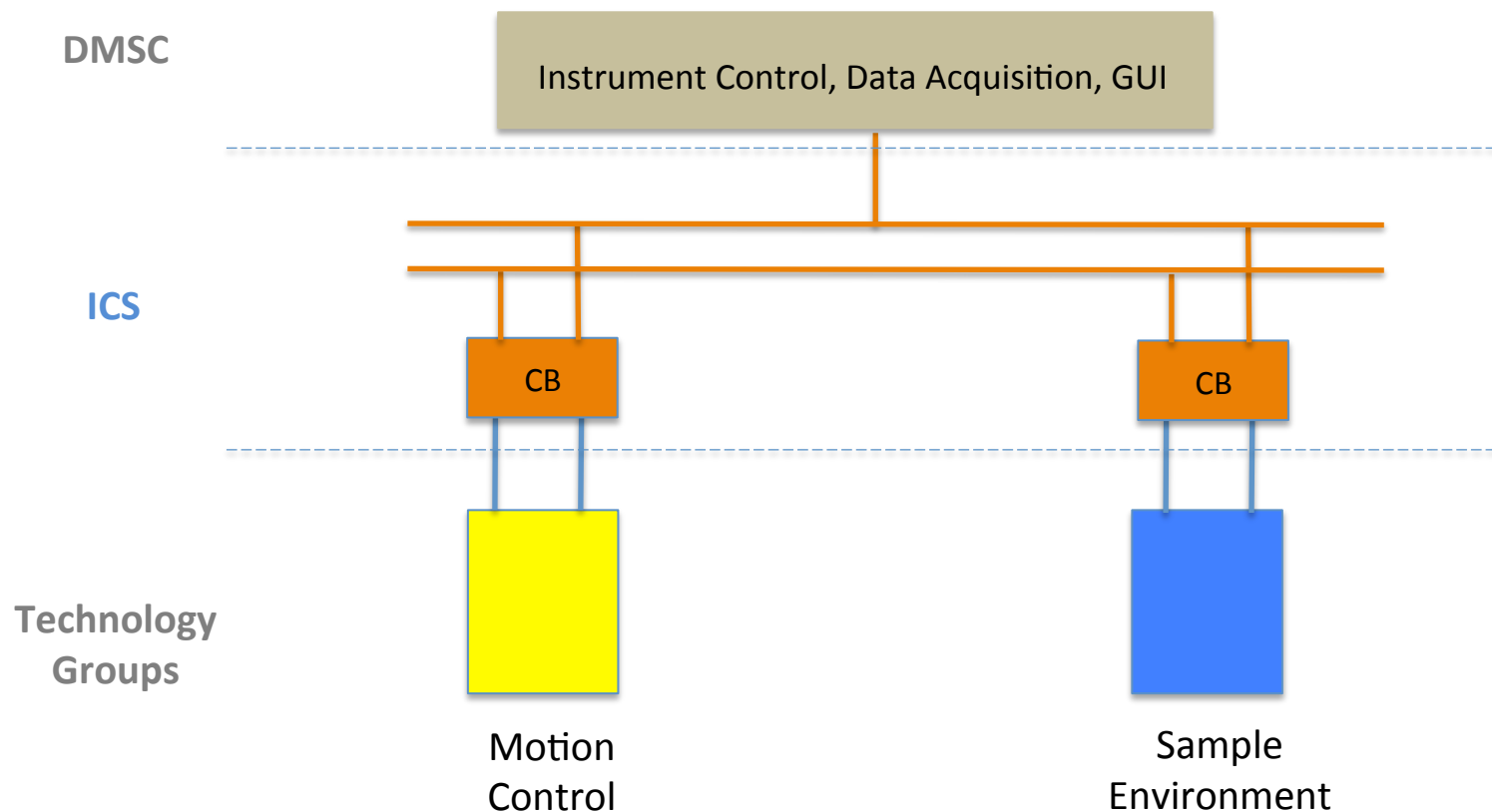

# Organisational Challenges: Internal Interfaces

- Strong interaction between machine and beam line tech groups
- Building overlapping interfaces

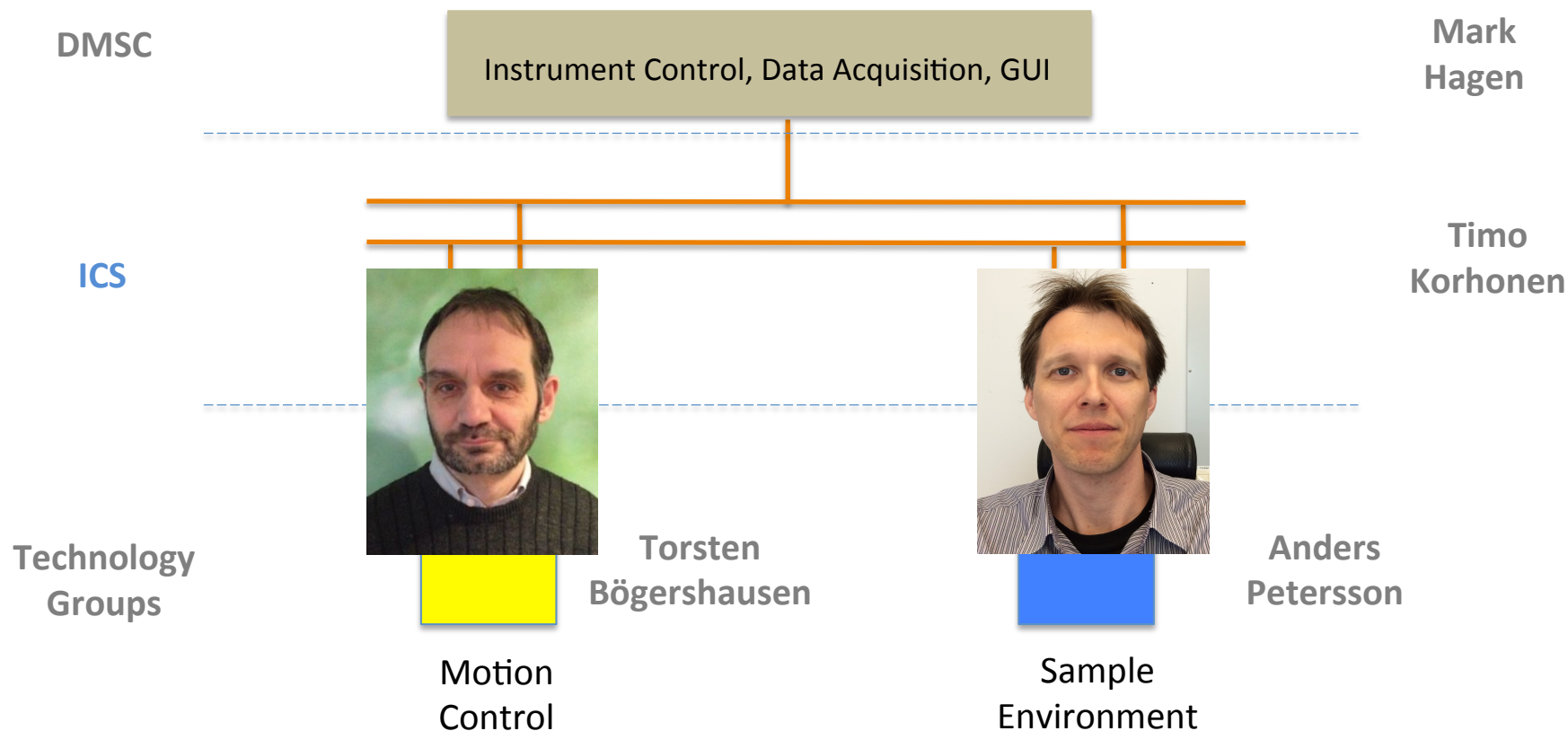

# Organisational Challenges: External

- 17 European partner countries
- 70 % of Neutron Instrumentation is in-kind
- Ranges from whole instruments to single modules
- Strong standardisation necessary (hardware list)  
+ good definition of functionality and interfaces
- Support of partners in testing their modules

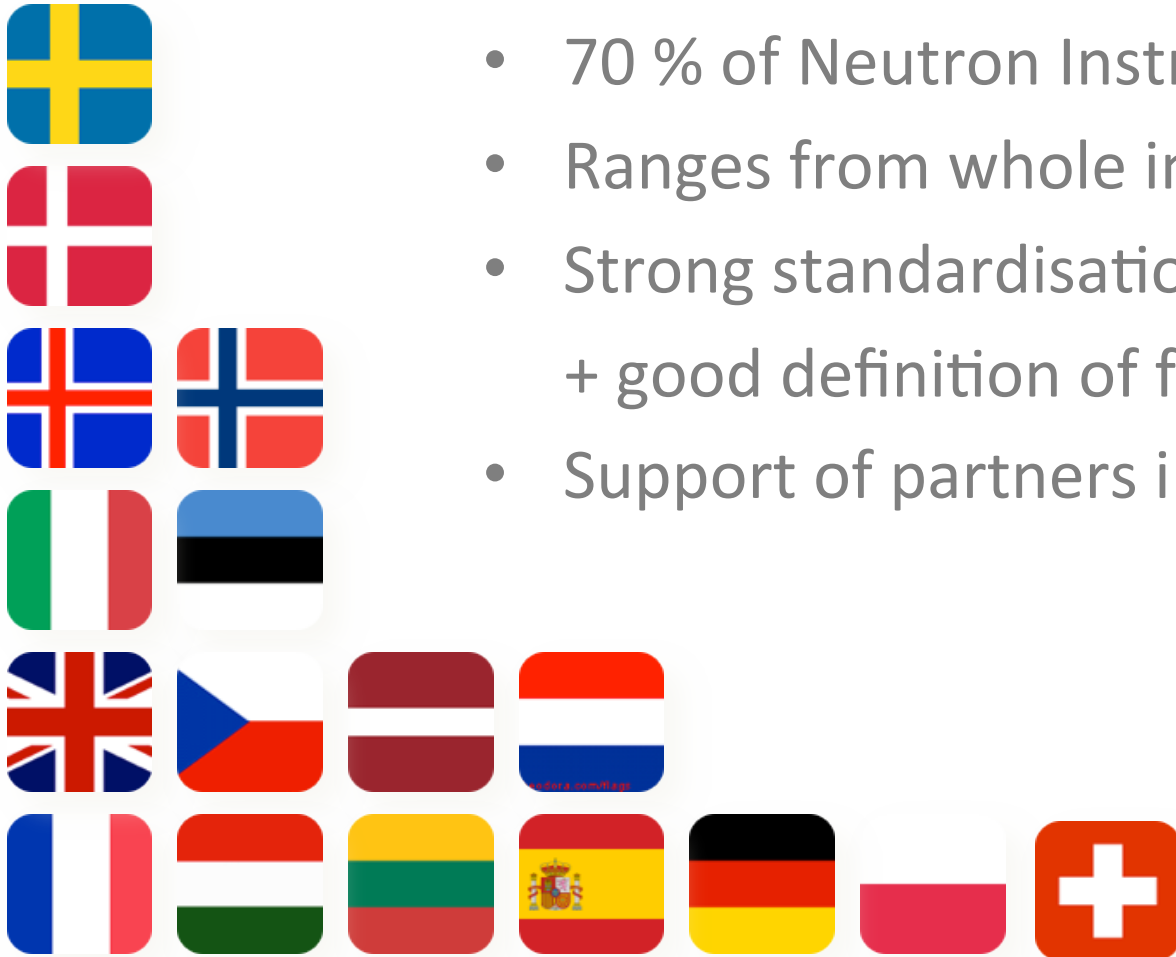

# Motion Control: Status

- Started with Delta Tau Geobrick for Test Stands and Demonstrators
- Market survey / Requirements catalog
- First steps in practical evaluation (Delta Tau Powerbrick, Beckhoff)
- Integration of a Beckhoff ETHERCAT system into EPICS (TwinCat)
- First application as chopper control demonstrator

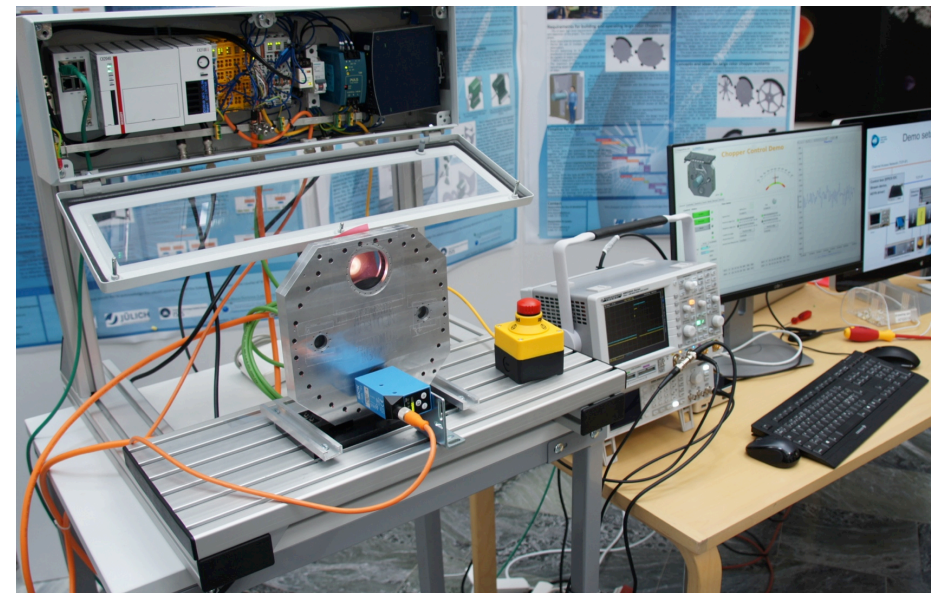
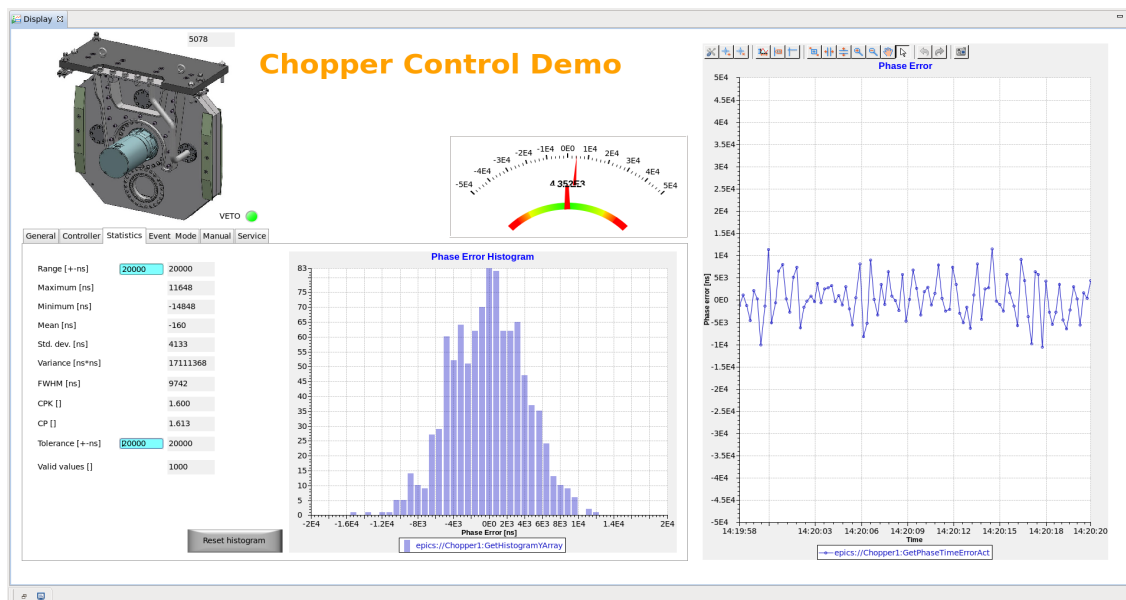

# Motion Control: A path to an ESS Standard

1. Hardware Harmonisation Work Group @ESS
2. Collecting use cases from stake holders
3. Refine requirements catalog
4. Select candidates for practical evaluation
5. Coordinate evaluation/selection with stake holders and collaborators
6. Workshop in 2015 (2<sup>nd</sup> half) >> common decision on MCU standard
7. Issue Standard Document Motor/Encoder
8. Issue Standard Document Motion Control Unit
9. Framework agreement with supplier (incl. possible deliveries to in-kind partners)



# Thanks to

- Motion Control & Automation Group  
(Anders Sandström, Paul Barron, Torsten Bögershausen, Markus Larsson)
- Sample Environments Group  
(Anders Petersson)
- Integrated Control Systems Division, Detector Group, Chopper Group, DMSC
- Other colleagues on various institutes and facilities  
(among others: Mark Könnecke-PSI, Steve Cox-ISIS, Brian Nutter-Diamond)

Thanks to



... and you!



# ESS Instrument Control

## - Details for Motion Control-

Thomas Gahl

Group Leader Motion Control & Automation

[www.europeanspallationsource.se](http://www.europeanspallationsource.se)

September 16, 2014

# Synchronising Motion Control (multiple axes)

- 14 Hz pulse (to synchronise movements with neutron pulse)
- 10 kHz as masterclock (to synchronise multi-axes systems)
- $\approx 1$  Hz or slower pulse + reading of the appropriated absolute time over EPICS (to synchronise internal timer)

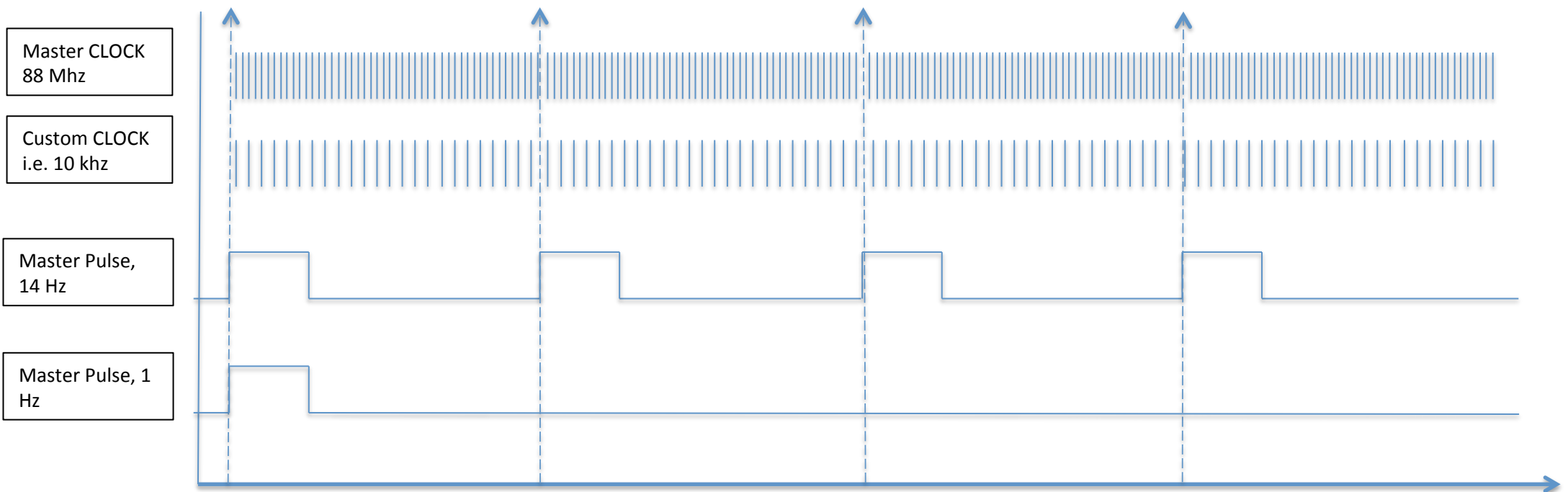

# Chopper Control Demo

- Development of a motion control for a ¼ scale chopper model and integration in an EPICS environment; interfaces and functionality according to ESS standards
- Demonstration model at IKON7 and DENIM conference in Munich, Germany

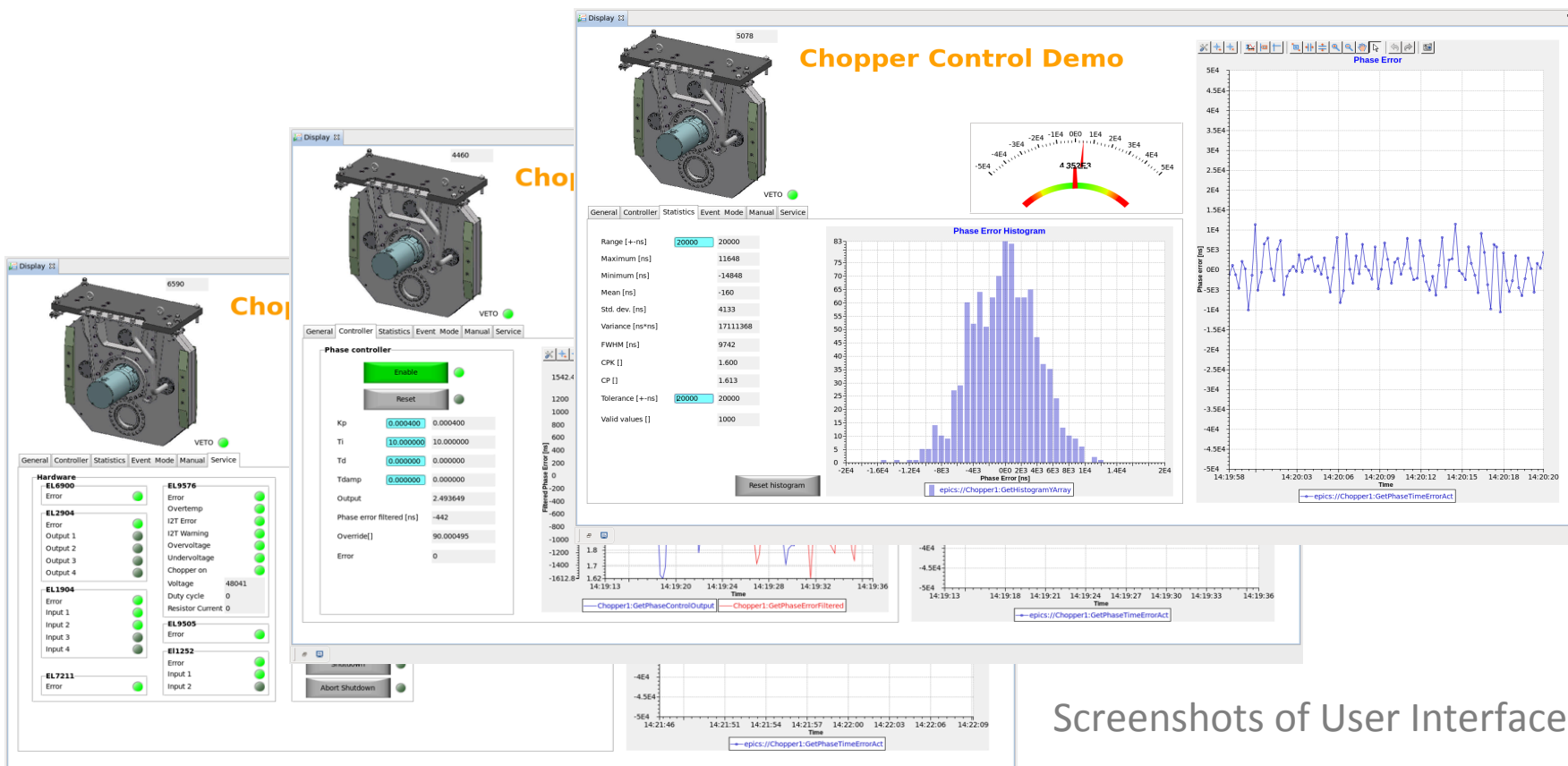

Screenshots of User Interfaces

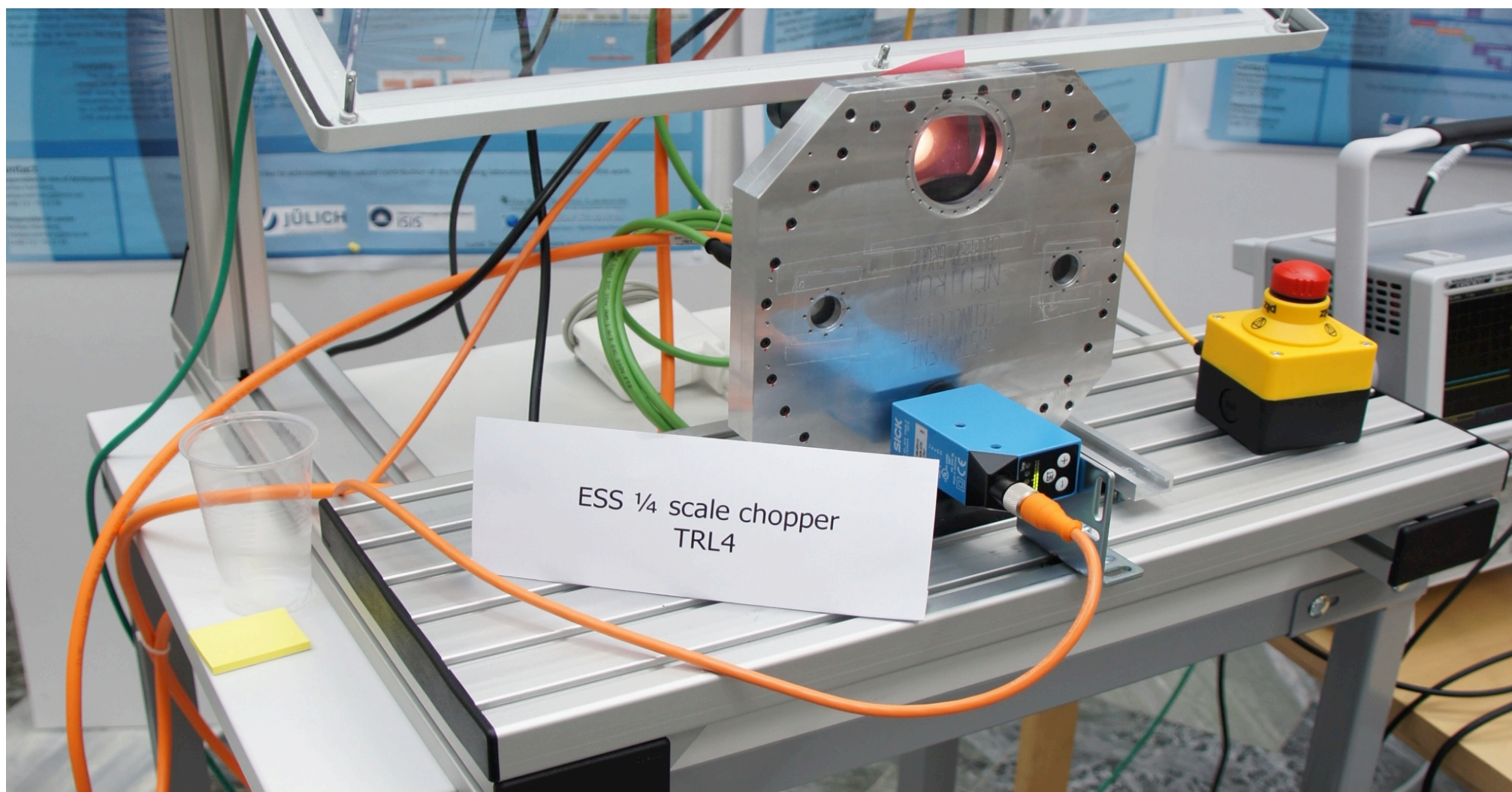

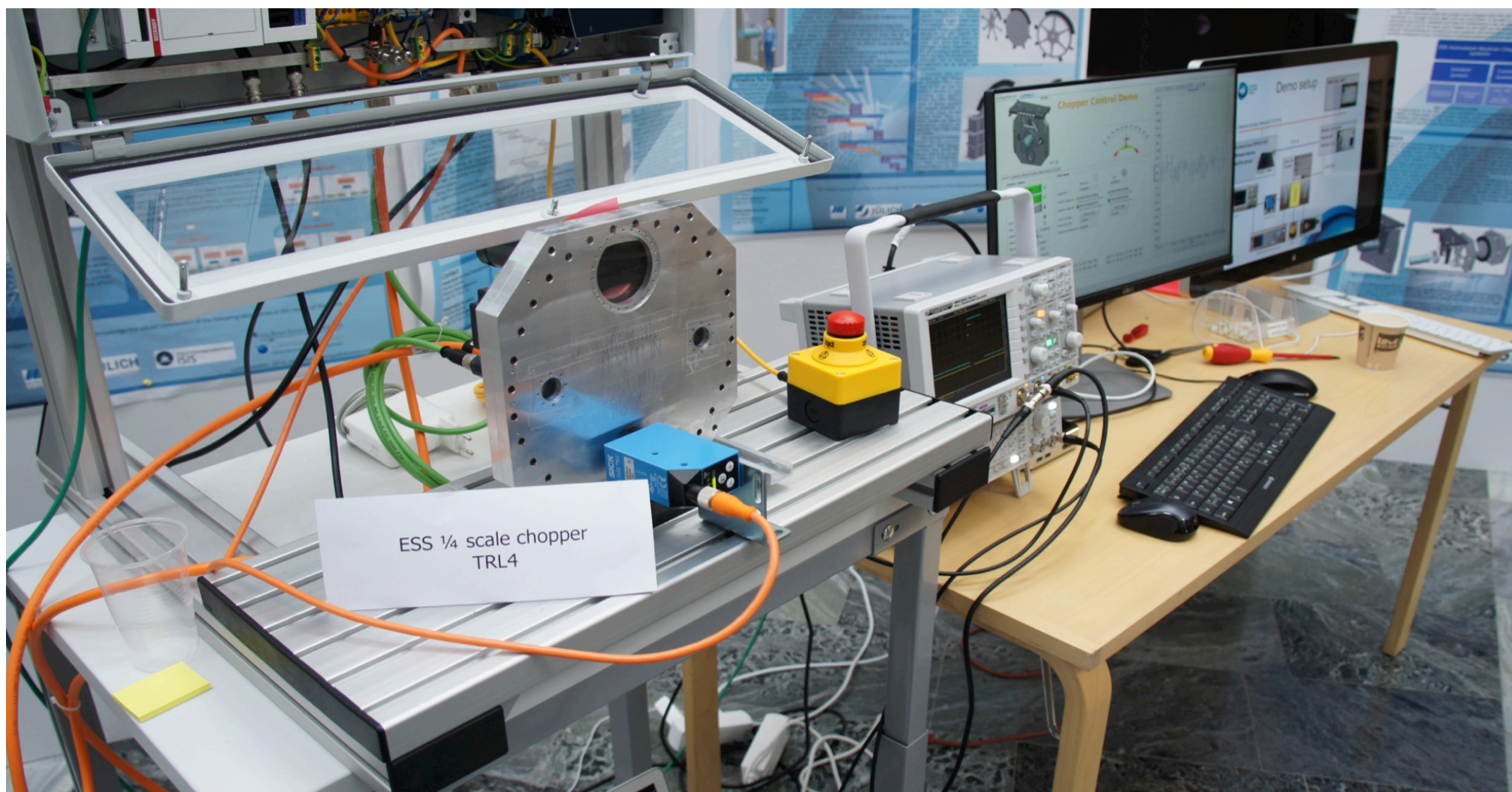

# ESS Instrument Control

## - Use cases-

Thomas Gahl  
Group Leader Motion Control & Automation

# Taking data on the fly

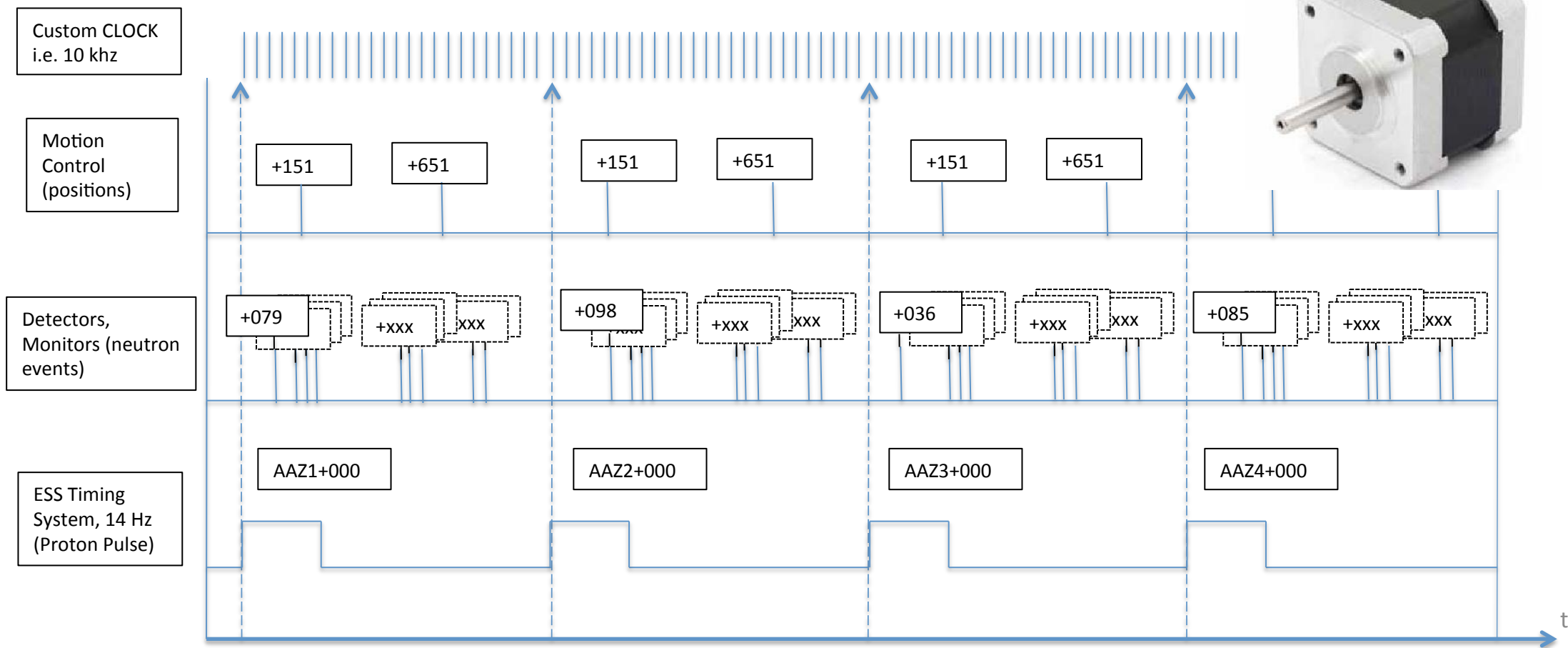

# Stroboscopic Mode (Sample Environment)

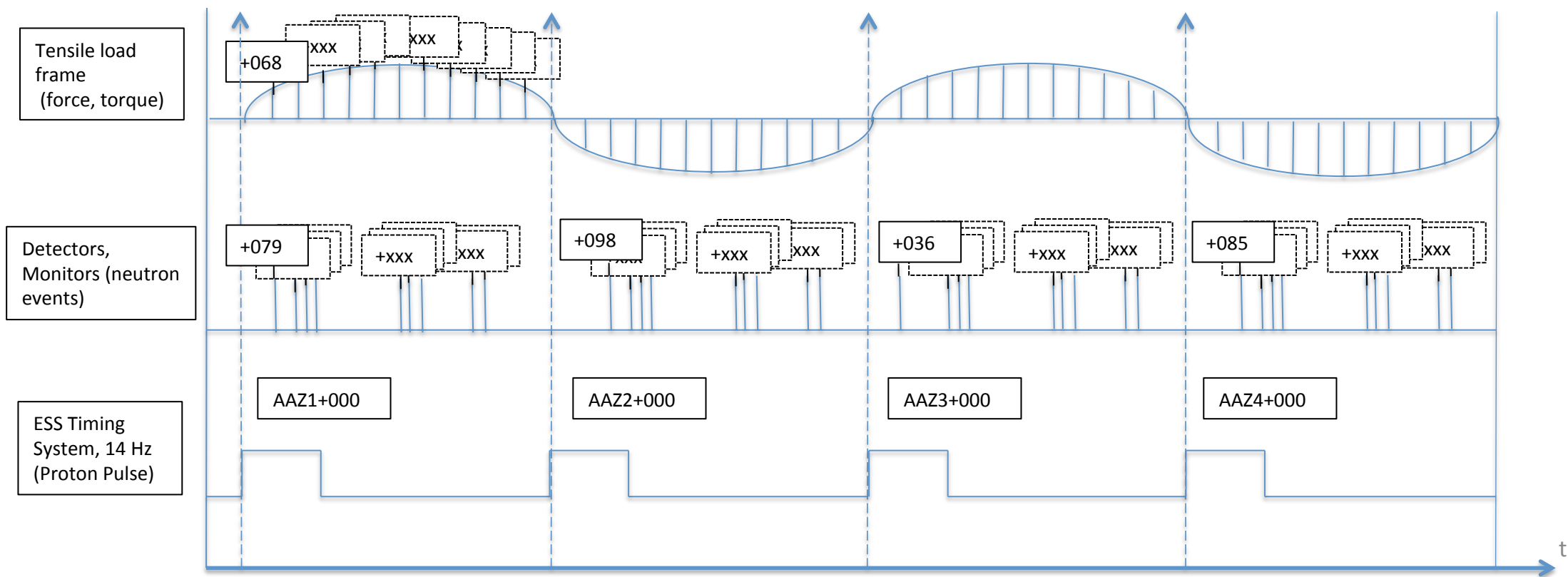



# Flexible Chopper Veto

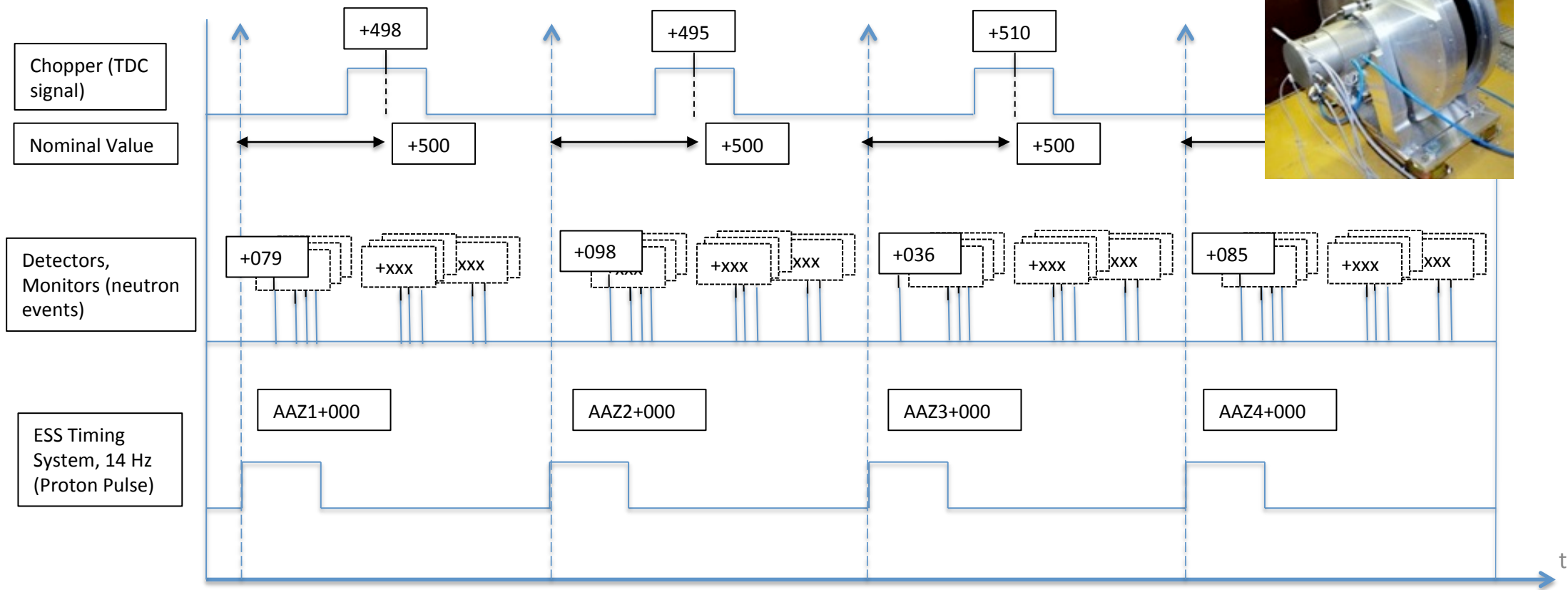
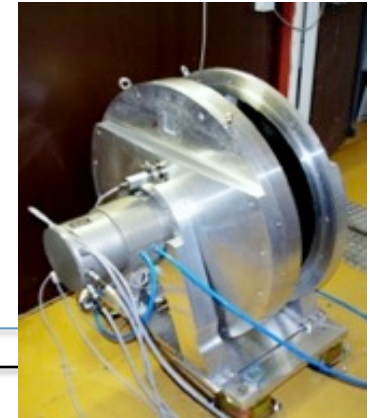

# Diagnostics (Chopper Systems and Beam Transport)

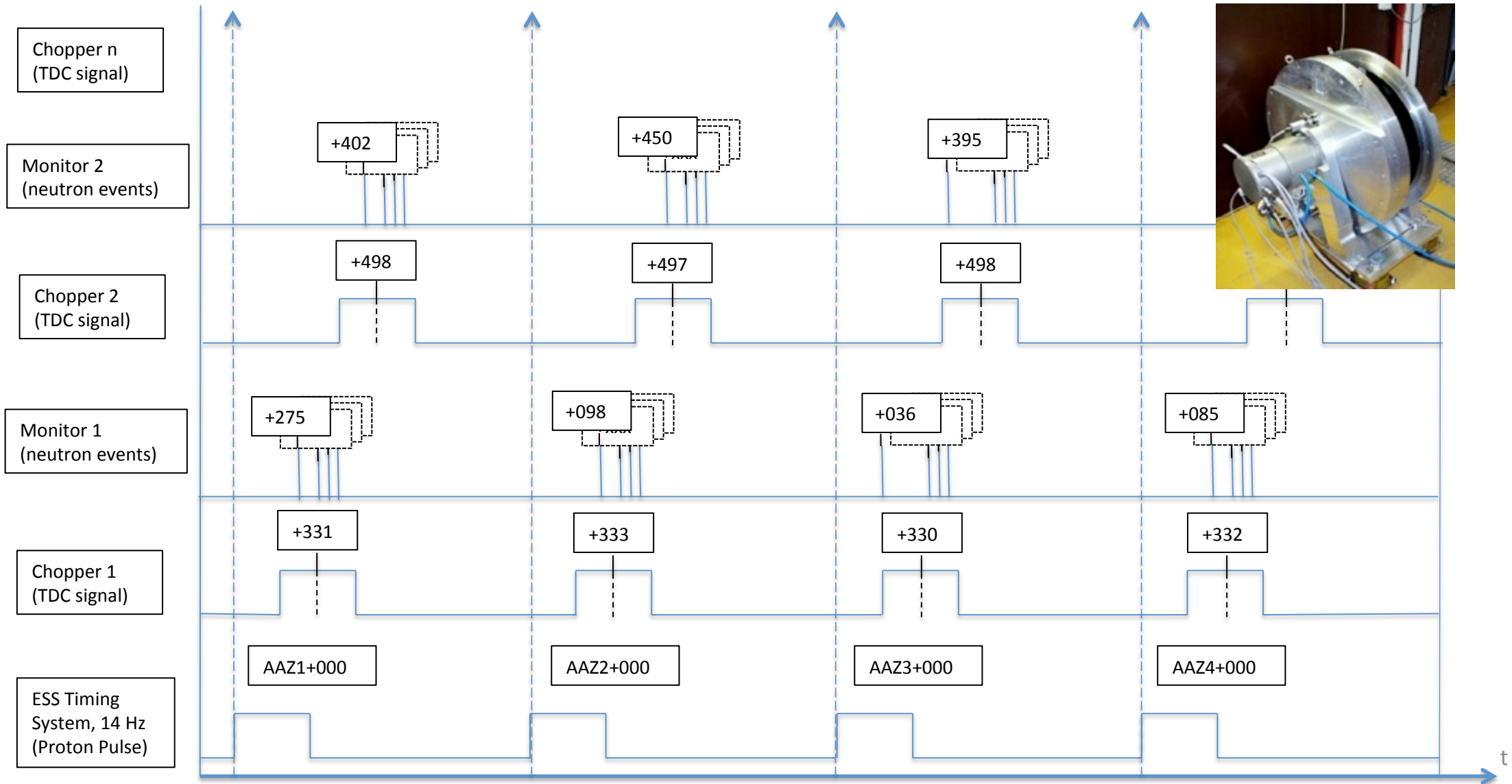

# Diagnostics (Wavelength Frame Multiplication Chopper)

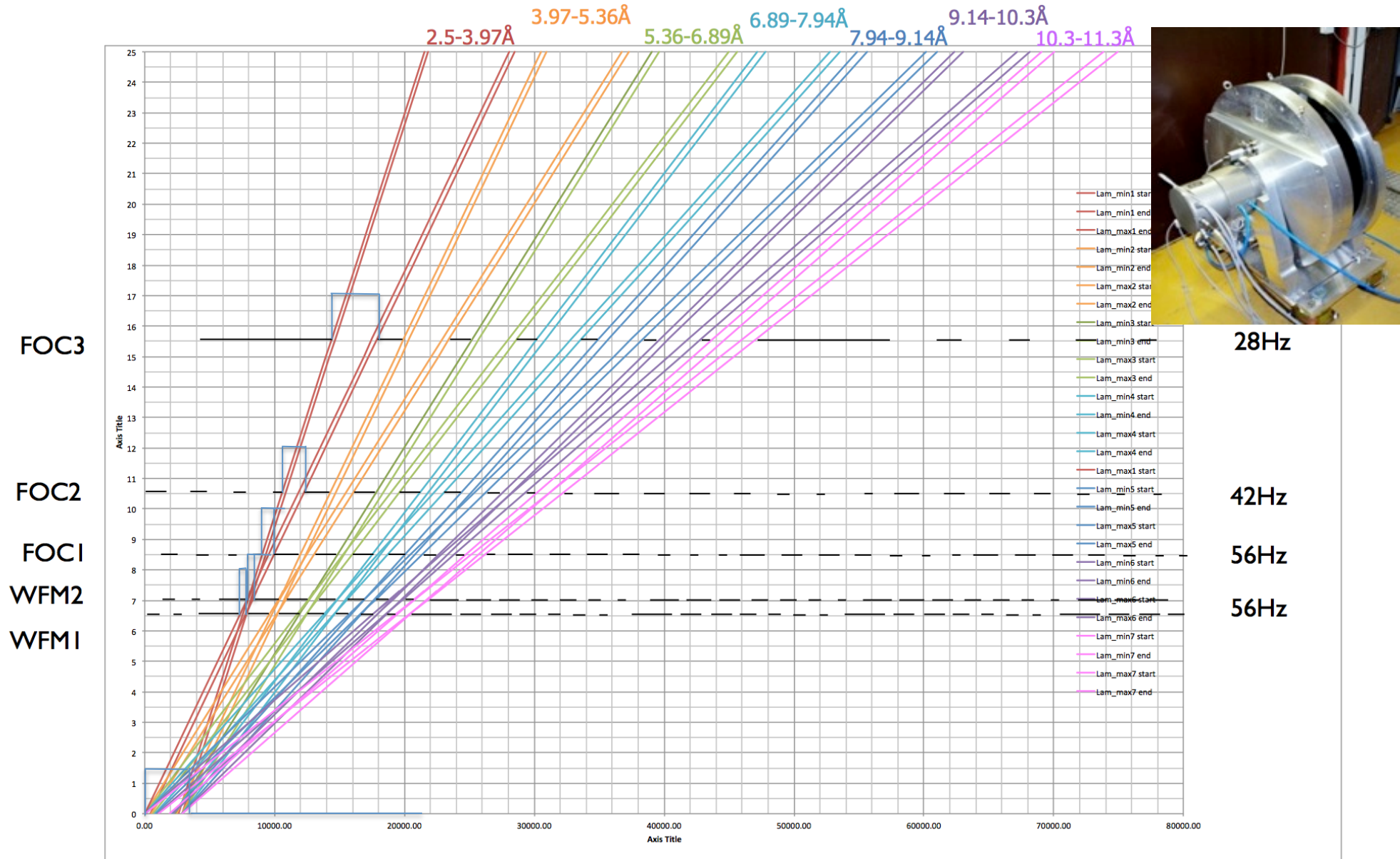

# Opportunities

- Well defined modularity
- Flexibility (Operation & Add-ons)
- Higher availability
- Better use of available beam time
- Recover data
- Advanced diagnostics

# Challenges & Risks

- Handling large data streams
- Failing of central services (like timing system)
- New kind of data mining / data sorting SW necessary, has to be adapted to each functionality individually
- Latency must be very well understood

# Time Stamping (Event Mode)

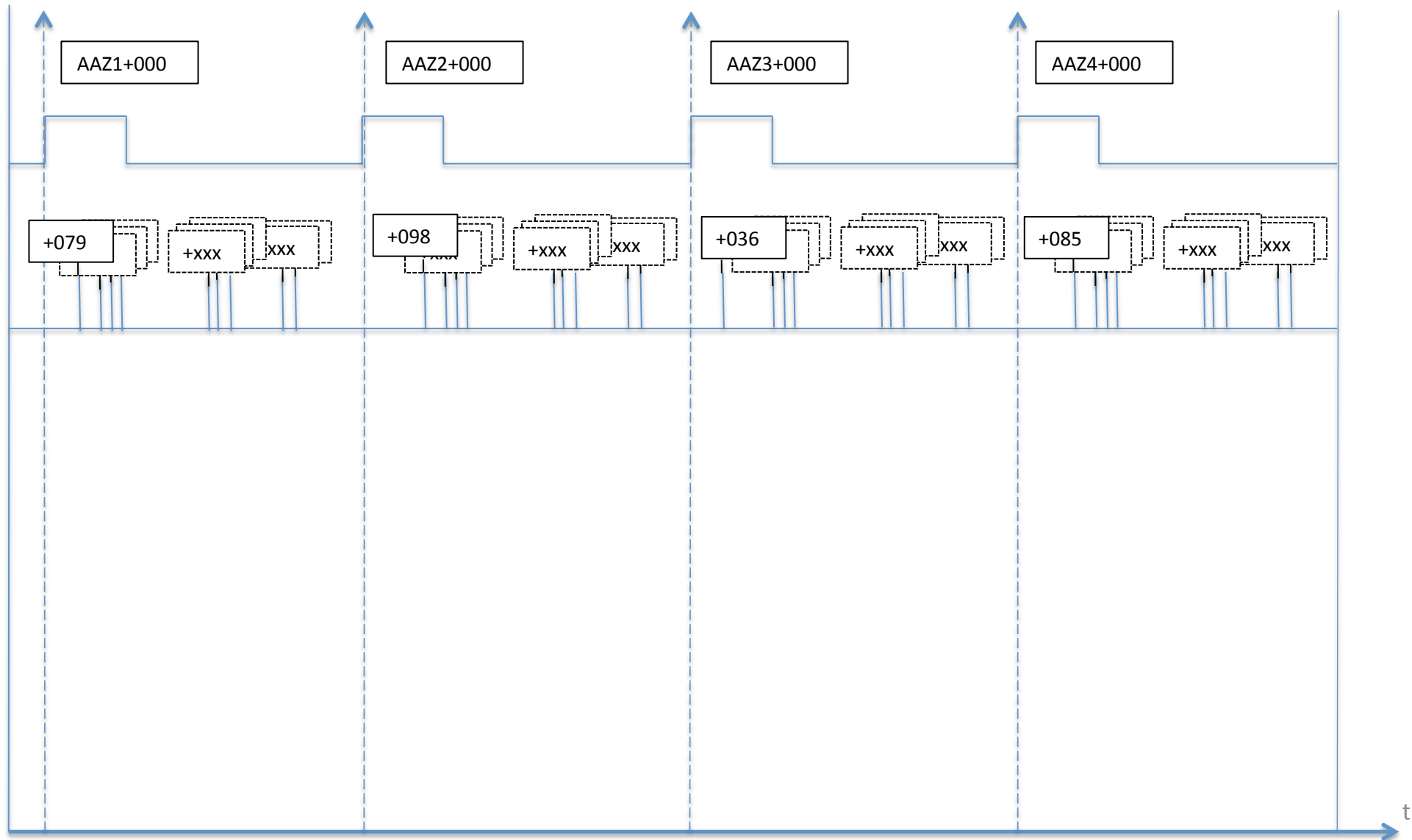

# Time Stamping (Event Mode)

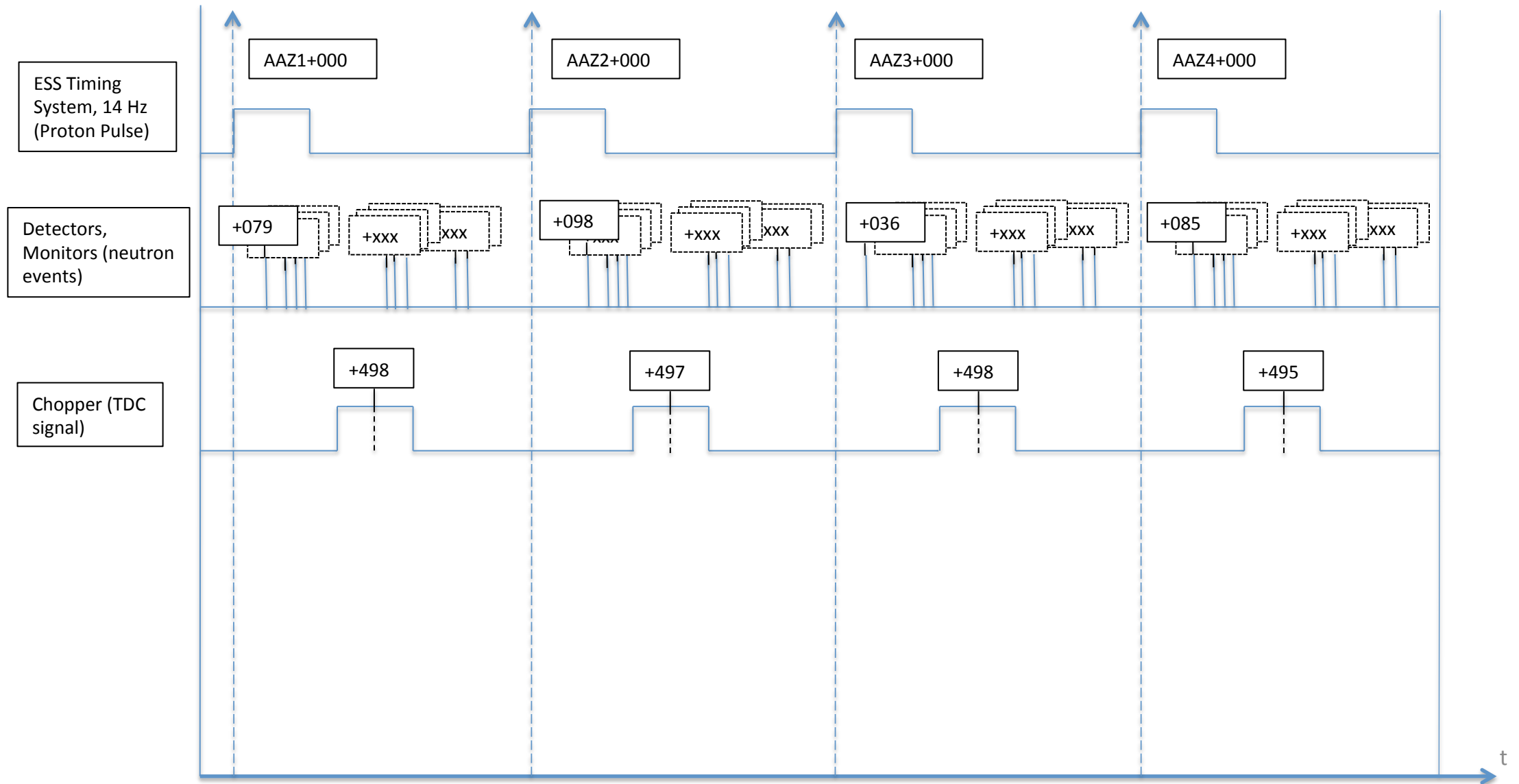

# Time Stamping (Event Mode)

ESS Timing System, 14 Hz (Proton Pulse)

Detectors, Monitors (neutron events)

Chopper (TDC signal)

Strain Scanner (force, torque)

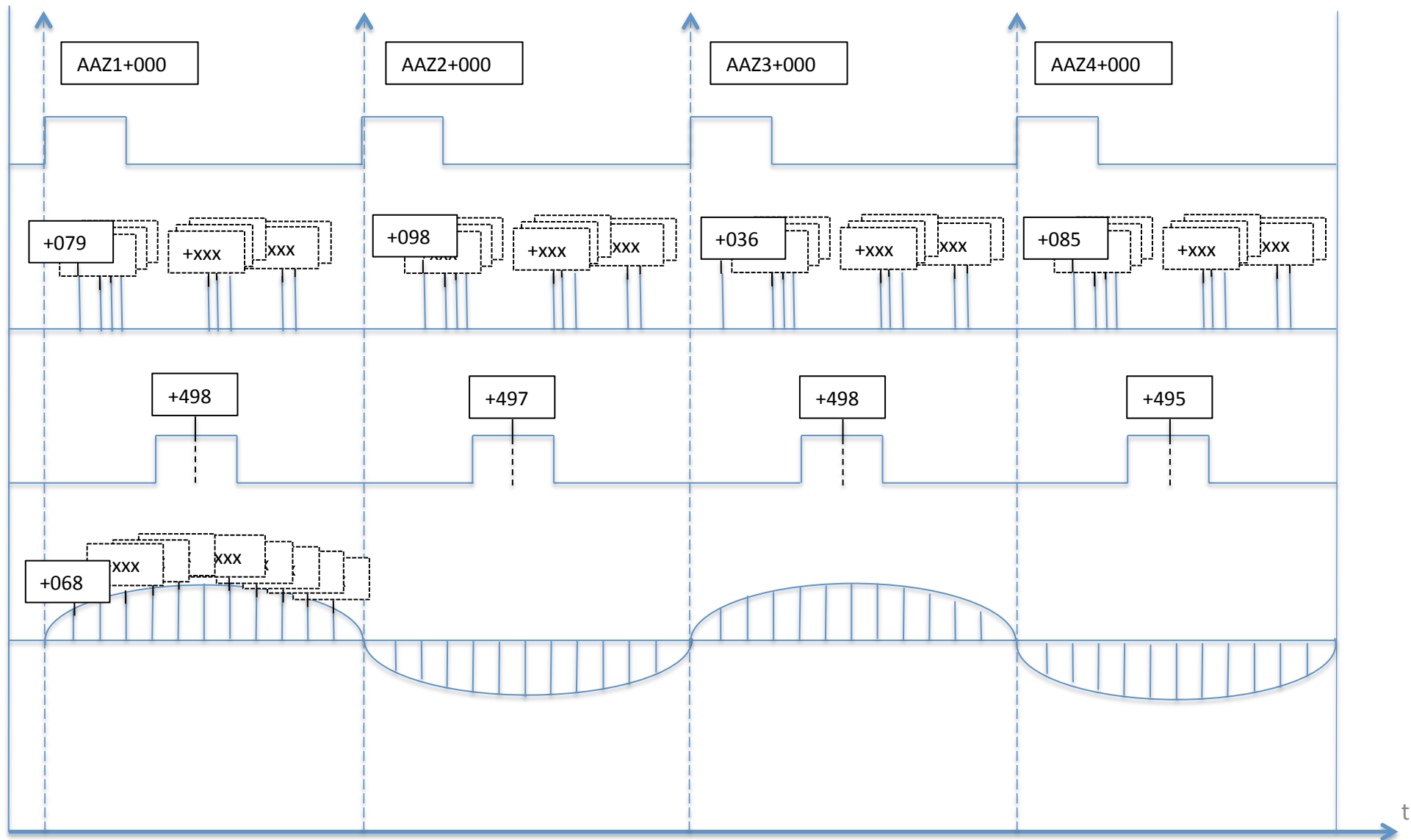



# Time Stamping (Event Mode)

